

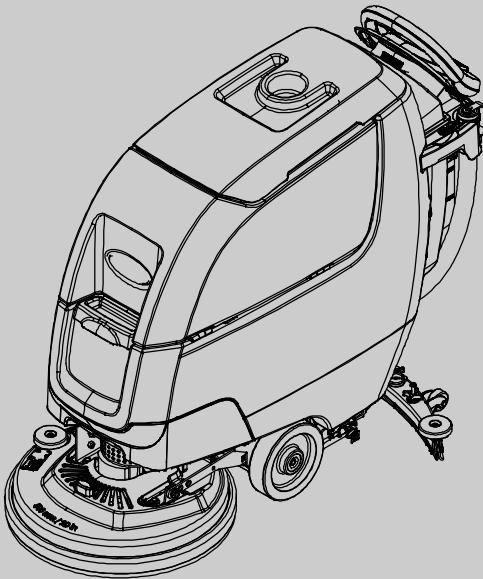

# T300e

Walk-Behind Floor Scrubber

English **EN**  
Operator Manual



*Hygenic*<sup>®</sup> Fully Cleanable Recovery Tank  
TennantTrue<sup>®</sup> Parts



## North America



For the latest Parts manuals and other  
language Operator manuals, visit:

[www.tennantco.com/manuals](http://www.tennantco.com/manuals)

9014506  
Rev. 03 (11-2023)



---

## INTRODUCTION

---

This manual is furnished with each new model. It provides necessary operation and maintenance instructions.



**Read this manual completely and understand the machine before operating or servicing it.**

This machine will provide excellent service. However, the best results will be obtained at minimum costs if:

- The machine is operated with reasonable care.
- The machine is maintained regularly - per the maintenance instructions provided.
- The machine is maintained with manufacturer supplied or equivalent parts.

To view, print or download manuals online visit [www.tennantco.com/manuals](http://www.tennantco.com/manuals)



### PROTECT THE ENVIRONMENT

Please dispose of packaging materials and used machine components such as batteries in an environmentally safe way according to your local waste disposal regulations.



Always remember to recycle.

**Tennant Company**  
10400 Clean Street  
Eden Prairie, MN 55344-2650  
USA  
Phone: (800) 553- 8033  
[www.tennantco.com](http://www.tennantco.com)

Trojan is a registered trademark of Trojan Battery Company.

Specifications and parts are subject to change without notice.

Original Instructions. Copyright ©2015- 2022 Tennant Company.  
All rights reserved.

---

## INTENDED USE

---

The automatic floor scrubber is intended for commercial use, for example in hotels, schools, hospitals, factories, shops, offices and rental businesses. It is designed to scrub hard floor surfaces (concrete, tile, stone, synthetic, etc.) in an indoor environment. This machine is not intended for cleaning carpets or sanding wood floors. Use only recommended pads/brushes and commercially available floor cleaning detergents. Do not use this machine other than described in this Operator Manual.

---

## MACHINE DATA

---

Please fill out at time of installation for future reference.

Model No. - \_\_\_\_\_

Serial No. - \_\_\_\_\_

Installation Date - \_\_\_\_\_

---

## SERIAL NUMBER LOCATION



---

## UNCRATING MACHINE

---

Carefully check machine for signs of damage. Report damages at once to carrier. Contact distributor or Tennant for missing items.

To uncrate the machine, remove straps, wheel blocks and shipping brackets. Using the supplied ramp carefully back the machine off the pallet. Make sure scrub head is in the raised position.

**ATTENTION: Do not remove machine from pallet without using ramp, machine damage may occur.**

## TABLE OF CONTENTS

<b>INTRODUCTION</b> .....	<b>2</b>	SERVICE INDICATOR CODES - Continued	22
<b>INTENDED USE</b> .....	<b>2</b>	ON-BOARD BATTERY CHARGER SERVICE	
<b>MACHINE DATA</b> .....	<b>2</b>	INDICATOR CODES .....	22
SERIAL NUMBER LOCATION .....	2	ec-H2O SYSTEM SERVICE INDICATOR CODES	
<b>UNCRATING MACHINE</b> .....	<b>2</b>	- OPTION .....	23
<b>TABLE OF CONTENTS</b> .....	<b>3</b>		
<b>OPERATION</b>		<b>MAINTENANCE</b>	
<b>IMPORTANT SAFETY INSTRUCTIONS</b> .....	<b>4</b>	<b>MAINTENANCE CHART</b> .....	<b>24</b>
<b>SAFETY LABELS</b> .....	<b>6</b>	<b>MACHINE MAINTENANCE</b> .....	<b>25</b>
<b>MACHINE COMPONENTS</b> .....	<b>7</b>	AFTER DAILY USE .....	25
<b>MACHINE SYMBOLS</b> .....	<b>8</b>	AFTER WEEKLY USE .....	26
<b>CONTROL PANEL COMPONENTS</b> .....	<b>8</b>	AFTER EVERY 50 HOURS OF USE .....	27
T300e Control Panel .....	8	AFTER EVERY 100 HOURS OF USE .....	27
<b>INSTALLING BATTERIES</b> .....	<b>9</b>	ELECTRIC MOTORS .....	27
LITHIUM- ION BATTERY .....	9	BELTS .....	28
FLOODED (WET) and MAINTENANCE- FREE		ORBITAL SCRUB HEAD ISOLATORS .....	28
SEALED LEAD- ACID BATTERIES .....	9		
BATTERY PACK LIFT- OUT TRAY (Option) .	9	<b>BATTERIES</b> .....	<b>28</b>
<b>HOW THE MACHINE WORKS</b> .....	<b>10</b>	FLOODED (WET) and MAINTENANCE- FREE	
<b>BRUSH AND PAD INFORMATION</b> .....	<b>10</b>	SEALED LEAD- ACID BATTERIES .....	28
<b>MACHINE SETUP</b> .....	<b>11</b>	CHECKING CONNECTIONS / CLEANING ..	29
CHARGE BATTERIES .....	11	LITHIUM- ion BATTERY .....	29
ATTACHING SQUEEGEE ASSEMBLY .....	11	BATTERY POWER BUTTON / BATTERY	
INSTALLING BRUSH/PAD - 3 Lug Disk .....	11	DISCHARGE INDICATOR .....	30
INSTALLING BRUSH/PAD - Insta-Click Magnetic		CHARGING BATTERIES .....	30
Disk (Option) .....	12	BATTERY CHARGER SETTINGS .....	31
INSTALLING PAD - Orbital .....	13	CHANGING ON- BOARD BATTERY CHARGER	
INSTALLING CYLINDRICAL BRUSHES .....	13	SETTINGS .....	31
FILLING SOLUTION TANK .....	14	MANUAL BATTERY WATERING SYSTEM	
ec-H2O NanoClean WATER CONDITIONING		(Trojan Battery OPTION) .....	33
CARTRIDGE (ec-H2O model) .....	15	<b>SQUEEGEE BLADE REPLACEMENT</b> .....	<b>34</b>
ACCESSORY RAIL .....	15	<b>ec-H2O NanoClean WATER CONDITIONING</b>	
<b>MACHINE OPERATION</b> .....	<b>16</b>	<b>CARTRIDGE REPLACEMENT</b> .....	<b>35</b>
PRE-OPERATION CHECK LIST .....	16	<b>LOADING/UNLOADING MACHINE FOR</b>	
OPERATING MACHINE .....	16	<b>TRANSPORTING</b> .....	<b>36</b>
WHILE OPERATING MACHINE .....	18	<b>STORING MACHINE</b> .....	<b>36</b>
EMERGENCY SHUT-OFF BUTTON (Drive		Freeze Protection .....	36
models) .....	18	<b>TROUBLESHOOTING</b> .....	<b>37</b>
BATTERY DISCHARGE INDICATOR .....	18	<b>GENERAL MACHINE</b>	
CIRCUIT BREAKER PANEL .....	19	<b>DIMENSIONS/CAPACITIES/PERFORMANCE ..</b>	<b>39</b>
HOUR METER .....	19	<b>GENERAL MACHINE</b>	
<b>DRAINING TANKS</b> .....	<b>20</b>	<b>DIMENSIONS/CAPACITIES/PERFORMANCE ..</b>	<b>40</b>
DRAINING RECOVERY TANK .....	20	<b>MACHINE DIMENSIONS</b> .....	<b>41</b>
DRAINING SOLUTION TANK .....	20		
<b>SERVICE INDICATOR CODES</b> .....	<b>21</b>		

---

### IMPORTANT SAFETY INSTRUCTIONS - SAVE THESE INSTRUCTIONS

---

The following warning precautions are used throughout this manual as indicated in their description:

**⚠ WARNING:** To warn of hazards or unsafe practices which could result in severe personal injury or death.

**FOR SAFETY:** To identify actions which must be followed for safe operation of equipment.

The following information signals potentially dangerous conditions to the operator. Know when these conditions can exist. Locate all safety devices on the machine. Report machine damage or faulty operation immediately.

**⚠ WARNING:** To Reduce the Risk of Fire, Explosion, Electric Shock or Injury:

- Read manual before operating machine.
- Do not use or pick up flammable materials.
- Do not use near flammable liquids, vapors or combustible dusts.  
This machine is not equipped with an explosion proof motor. The electric motor will spark upon start up and during operation which could cause a flash fire or explosion if machine is used in an area where flammable vapors/liquids or combustible dusts are present.
- Batteries emit hydrogen gas. Explosion or fire can result. Keep sparks and open flame away when charging.
- Disconnect battery cables and charger cord before cleaning and servicing machine.
- Do not charge batteries with damaged cord. Do not modify plug.

If the charger supply cord is damaged or broken, it must be replaced by the manufacturer or its service agent or a similarly qualified person in order to avoid a hazard.

- Do not use outdoors. Store indoors.
- Spinning pad/brush, keep hands away.

**⚠ WARNING:** Magnetic Field Hazard. Magnetic pad driver/brush can be harmful to pacemaker wearers or medical implants.

IRIS Telemetry (option): This machine may be equipped with technology that automatically communicates over the cellular network. If the machine will be operated where cell phone use is restricted because of concerns related to equipment interference, please contact a Tennant representative for information on how to disable the cellular communication functionality.

#### FOR SAFETY:

1. Do not operate machine:
  - Unless trained and authorized.
  - Unless operator manual is read and understood.
  - Unless mentally and physically capable of following machine instructions.
  - Under the influence of alcohol or drugs.
  - While using a cell phone or other types of electronic devices.
  - If not in proper operating condition.
  - In outdoor areas. This machine is for indoor use only.
  - In areas where flammable vapors/liquids or combustible dusts are present.
  - With pads or accessories not supplied or approved by Tennant. The use of other pads may impair safety.
  - In areas with possible falling objects.
  - In areas that are too dark to safely see the controls or operate machine.
2. Before operating machine:
  - Check machine for fluid leaks.
  - Make sure all safety devices are in place and operate properly.
3. When operating machine:
  - Use only as described in this manual.
  - Report machine damage or faulty operation immediately.
  - Wear closed-toe, non-slip work shoes.
  - Reduce speed when turning.
  - Go slowly on inclines and slippery surfaces.
  - Do not scrub on inclines that exceed 9% grade or transport on inclines that exceed 21% grade.
  - Follow site safety guidelines concerning wet floors.
  - Follow mixing, handling and disposal instructions on chemical containers.
  - Do not carry passengers on machine.
  - Use care when reversing machine.
  - Keep children and unauthorized persons away from machine.
  - Do not allow machine to be used as a toy.

4. **Before leaving or servicing machine:**
  - Stop on level surface.
  - Set the parking brake, if equipped.
  - Turn off machine and remove key.
5. **When servicing machine:**
  - Disconnect battery connection and charger cord before working on machine.
  - All work must be done with sufficient lighting and visibility.
  - All repairs must be performed by trained personnel.
  - Use Tennant supplied or approved replacement parts.
  - Do not modify the machine from its original design.
  - Do not jack up machine.
  - Avoid moving parts. Do not wear loose clothing or jewelry and secure long hair.
  - Do not disconnect the off-board charger's DC cord from the machine's receptacle when the charger is operating. Arcing may result. If the charger must be interrupted during charging cycle, disconnect the AC power supply cord first.
  - Do not use incompatible battery chargers as this may damage battery packs and potentially cause a fire hazard.
  - Inspect charger cord regularly for damage.
  - Keep work area well ventilated.
  - Avoid contact with battery acid.
  - Keep all metal objects off batteries.
  - Do not power spray or hose off machine.
  - Use a hoist or adequate assistance when lifting batteries.
  - Battery installation must be done by trained personnel.
  - Wear personal protection equipment as needed and where recommended in this manual.
6. **When loading/unloading machine onto/off truck or trailer:**
  - Drain tanks before loading machine.
  - Use a ramp, truck or trailer that can support the machine weight and operator.
  - Do not operate the machine on a ramp incline that exceeds a 21% grade level.
  - Use a winch if ramp incline exceeds a 21% grade level.
  - Lower the scrub head and squeegee before tying down machine.
  - Turn machine off and remove key.
  - Set parking brake (if equipped).
  - Block machine wheels.
  - Use tie-down straps to secure machine.
7. **When using Lithium-ion Battery Model:**
  - Battery service to be performed by Tennant Service only.
  - Battery is designed exclusively for specific Tennant machine applications. Do not install battery in unapproved machines.
  - Dispose of battery in accordance with local regulations. Contact Tennant Service.
  - Contact Tennant Service or your local regulatory authorities for proper transporting instructions of lithium-ion batteries.
  - Use only OEM approved battery charger supplied with lithium-ion battery.
  - Do not expose battery to temperatures below -4°F/-20°C, above 140°F/60°C.
  - Do not use machine immediately after long-term extreme temperature storage. Before use, return battery module temperature range to 50°F/10°C~95°F/35°C
  - Do not operate or store battery in hazardous environment (electrically charged, humidity, extreme temperatures and magnetic fields).
  - Do not expose battery to flame or plasma.
  - Do not disassemble or mistreat battery. Do not tear seal tape or will void warranty.
  - Do not drop, crush or subject battery to impact, as it may cause battery to heat up or catch fire.
  - Do not put battery in fire or water to avoid battery explosion.
  - Do not touch battery with wet hand, avoid electric shock.
  - Stop using or charging the battery immediately if battery has abnormal temperature, leakage or other abnormal conditions.



**For Safety: wear protective gloves.**



**For Safety: wear eye protection.**

# OPERATION

## SAFETY LABELS

The safety labels appear on the machine in the locations indicated. Replace labels if they are missing or become damaged or illegible.

**WARNING LABEL -** Located on recovery tank cover.

⚠️ <b>WARNING</b>		⚠️ <b>AVERTISSEMENT</b>		⚠️ <b>ADVERTENCIA</b>	
	<b>TO REDUCE THE RISK OF FIRE, EXPLOSION, ELECTRICAL SHOCK, OR INJURY:</b> <ul style="list-style-type: none"> <li>• Read manual before operating machine.</li> <li>• Do not use or pick up flammable materials.</li> <li>• Do not use near flammable liquids, vapors or combustible dusts.</li> <li>• Batteries emit hydrogen gas. Explosion or fire can result. Keep sparks and open flame away when charging.</li> <li>• Disconnect battery cables and charger plug before servicing machine.</li> <li>• Do not charge batteries with damaged cord.</li> <li>• Do not use outdoors. Store indoors.</li> </ul>		<b>POUR RÉDUIRE LES RISQUES D'INCENDIE, L'EXPLOSION, DE CHOC ÉLECTRIQUE OU DE LESSURE:</b> <ul style="list-style-type: none"> <li>• Lisez le manuel avant d'utiliser la machine.</li> <li>• N'utilisez pas ou ne ramassez pas de matériaux inflammables.</li> <li>• N'utilisez pas près de liquides, vapeurs ou poussières inflammables.</li> <li>• Les batteries émettent de l'hydrogène gazeux. Risque d'incendie et d'explosion. Évitez toute étincelle et toute flamme nue lors de la charge des batteries.</li> <li>• Débranchez les câbles des batteries et le cordon du chargeur avant l'entretien de la machine.</li> <li>• Ne chargez pas les batteries avec un cordon endommagé.</li> <li>• N'utilisez pas à l'extérieur. Entreposez-la à l'intérieur.</li> </ul>		<b>PARA REDUCIR EL RIESGO DE INCENDIO, EXPLOSION, CHOQUE ELÉCTRICO, O LESIONES:</b> <ul style="list-style-type: none"> <li>• Lea el manual antes de utilizar la máquina.</li> <li>• No utilice ni recoja materiales inflamables.</li> <li>• No utilice la máquina cerca de líquidos, polvos o vapores inflamables.</li> <li>• Las baterías emiten hidrógeno. Peligro de incendio o explosión. Mantenga la máquina alejada de chispas y llamas cuando se esté cargando.</li> <li>• Desconecte los cables de la batería antes de realizar el servicio a la máquina.</li> <li>• No cargue las baterías si el cable está dañado.</li> <li>• No utilice la máquina al aire libre. Guárdela en un lugar cerrado.</li> </ul>
					
					
					

1215281



**FOR SAFETY LABEL -** Do not power spray or hose off machine. Electrical malfunction may occur.

Located on control console

	<b>⚠️ WARNING</b> Spinning Pad. Keep Hands Away.
	<b>⚠️ AVERTISSEMENT</b> Patin En Rotation. Éloignez Vos Mains.
	<b>⚠️ ADVERTENCIA</b> Almohadilla Giratoria. Mantenga Alejadas Las Manos.

1208788

**WARNING LABEL -** Spinning pad. Keep hands away.

Located on disk scrub head model.

	<b>⚠️ WARNING</b> Spinning Brush. Keep Hands Away.
	<b>⚠️ AVERTISSEMENT</b> Brosse En Rotation. Éloignez Vos Mains.
	<b>⚠️ ADVERTENCIA</b> Cepillo Giratorio. Mantenga Alejadas Las Manos.

1215780

**WARNING LABEL -** Spinning brush. Keep hands away.

Located on cylindrical scrub head model.



**WARNING LABEL -** Batteries emit hydrogen gas. Explosion or fire can result. Keep sparks and open flame away when charging.

Located on bottom side of recovery tank.



**WARNING LABEL -** Magnetic Field Hazard. Magnetic pad driver/brush can be harmful to pacemaker wearers or medical implants.

Located on Insta-Click magnetic pad driver/brush.



**WARNING LABEL -** Electrical hazard. Disconnect battery cables before servicing machine.

Located on circuit breaker panel.

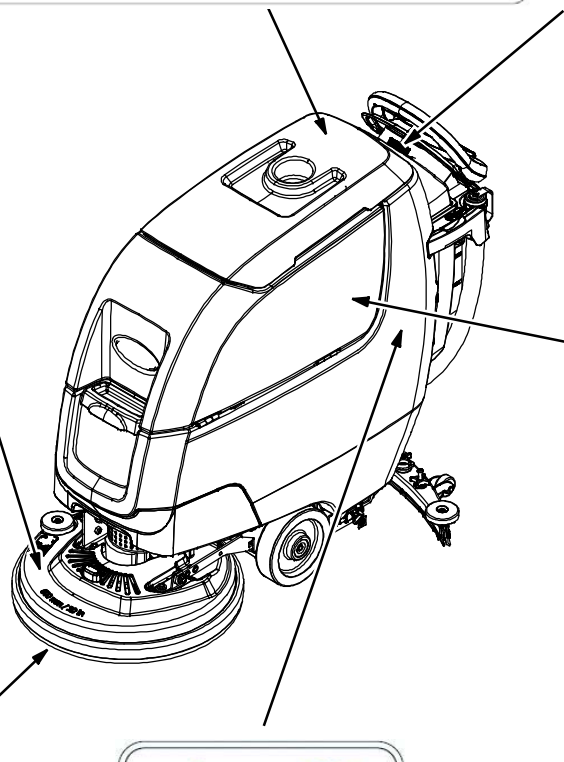



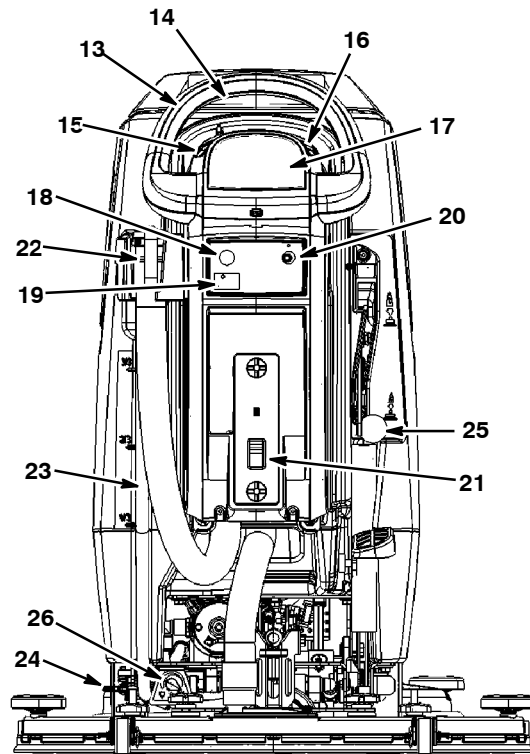
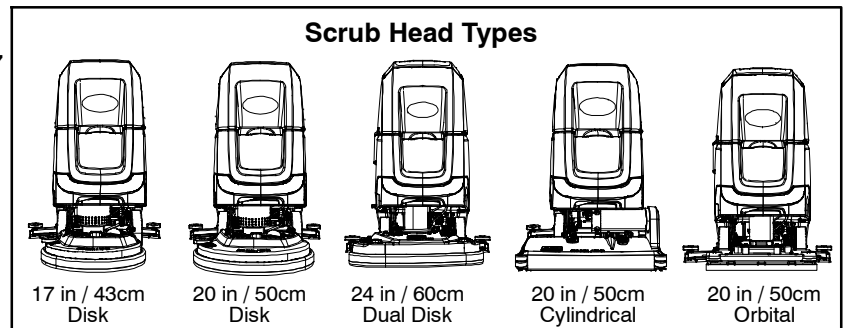
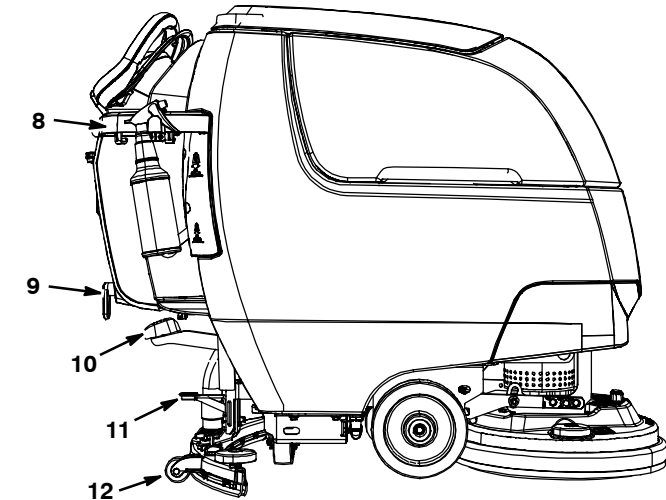
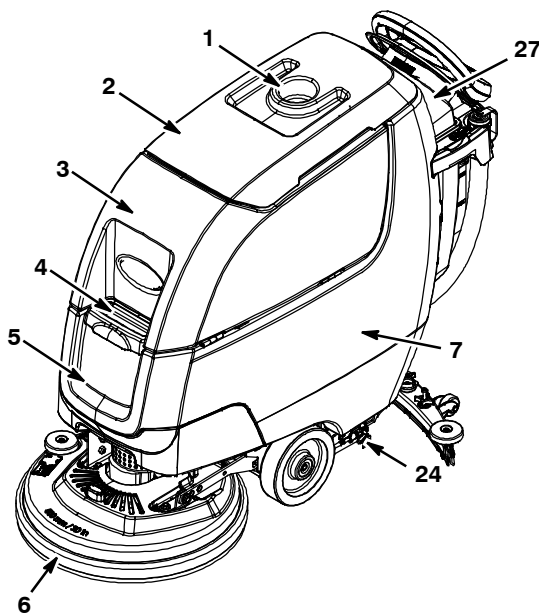









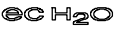
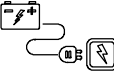

MACHINE COMPONENTS

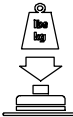

- |   |  |
|---|--|
| <ol style="list-style-type: none"> <li>1. Cup holder/tray</li> <li>2. Recovery tank lid</li> <li>3. Recovery tank</li> <li>4. Solution tank fill-port</li> <li>5. Solution tank</li> <li>6. Scrub head</li> <li>7. Battery compartment</li> <li>8. Accessory rail(s)</li> <li>9. On-board battery charger cord hooks</li> <li>10. Scrub head lift pedal</li> <li>11. Squeegee foot pad</li> <li>12. Squeegee assembly</li> <li>13. Control handle</li> <li>14. Control handle start bail</li> <li>15. Speed control knob (drive model)</li> <li>16. Forward/Reverse lever (drive model)</li> <li>17. Control panel display</li> <li>18. Emergency stop button (option)</li> </ol> | <ol style="list-style-type: none"> <li>19. Hour meter</li> <li>20. Key switch</li> <li>21. Off-board battery charger receptacle</li> <li>22. Recovery tank drain hose</li> <li>23. Solution tank level/drain hose</li> <li>24. Parking brake (option)</li> <li>25. Dual down pressure lever (option)</li> <li>26. Solution flow control knob</li> <li>27. Circuit breaker panel splash guard.</li> </ol> |
|---|--|

# OPERATION

## MACHINE SYMBOLS

	Fast speed (drive model)
	Slow speed (drive model)
	Forward / Reverse (drive model)
	On
	Off
	ec-H2O scrubbing (option)
	Battery charge
	Do not lift by accessory rails
	No step
	Dual down pressure
	Parking brake (option)
	No detergent (ec-H2O option)
	Water temperature (ec-H2O option)
	Solution flow
	No Solution flow
	Circuit breaker
	Cloud Connectivity (Telemetry option)

## CONTROL PANEL COMPONENTS

### T300e Control Panel

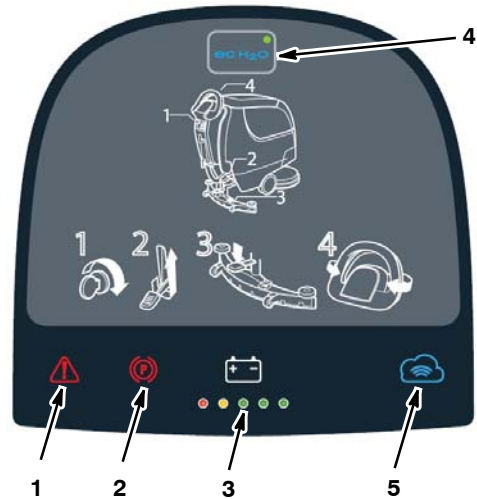

1. **Service indicator** - Lights up when a machine or charger fault is detected.
2. **Parking brake indicator (option)** - Lights up when parking brake lever is engaged. To turn off indicator, disengage parking brake lever near left rear wheel.
3. **Battery discharge indicator (BDI)** - The battery discharge indicator serves two functions. In normal scrub mode it displays the charge level of the batteries. It also, in conjunction when the service indicator is flashing, provides specific LED codes when a machine or charger fault is detected.
4. **ec-H2O button / indicator (Option)** - A blue ec- H2O indicator appears when the machine is equipped with ec- H2O option.
5. **Telemetry Connectivity indicator (Option)** - Lights up blue when machine is connected to the cloud.

## INSTALLING BATTERIES

### LITHIUM-ION BATTERY

For machines equipped with lithium-ion battery, contact Tennant Service for battery service and replacement.

**FOR SAFETY:** When using lithium-ion battery model, battery service to be performed by Tennant Service only.

### FLOODED (WET) AND MAINTENANCE-FREE SEALED LEAD-ACID BATTERIES

**⚠ WARNING:** Batteries emit hydrogen gas. Explosion or fire can result. Keep sparks and open flame away when charging.

**FOR SAFETY:** When servicing machine, wear appropriate personal protection equipment as needed. Avoid contact with battery acid.

### BATTERY SPECIFICATIONS

Two 12 volt deep-cycle batteries.

Contact distributor or Tennant for battery recommendations.

**FOR SAFETY:** Before leaving or servicing machine, stop on level surface, turn off machine, remove key and set parking brake if equipped.

1. Lift the recovery tank to access the battery compartment (Figure 1).

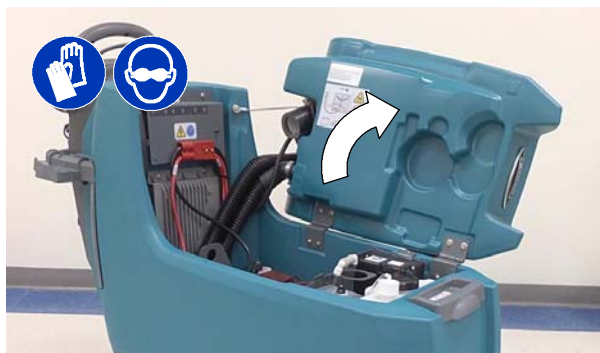

FIG. 1

2. With adequate assistance, carefully install the batteries into the battery compartment. Arrange the batteries as shown (Figure 2).

**FOR SAFETY:** When servicing machine, use a hoist or adequate assistance when lifting batteries.

3. Using the supplied battery post boots, connect the cables to the battery posts as shown (Figure 2). Connect the machine's black (-) battery cable last. Use insulated tools when working near batteries.

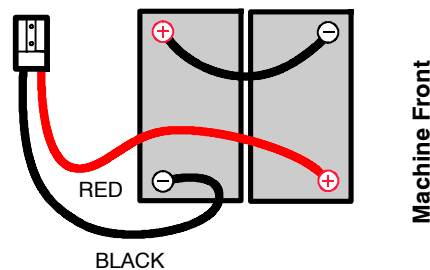

FIG. 2

**IMPORTANT:** Make sure that the machine's battery charger is properly set before charging. See BATTERY CHARGER SETTINGS.

### BATTERY PACK LIFT-OUT TRAY (Option)

Models equipped with the optional battery lift-out tray for quick or frequent battery pack exchange.

**FOR SAFETY:** Before leaving or servicing machine, stop on level surface, turn off machine, remove key and set parking brake if equipped.

**⚠ WARNING:** Batteries emit hydrogen gas. Explosion or fire can result. Keep sparks and open flame away when charging.

1. Disconnect the battery cable connection at machine (Figure 3).



FIG. 3

**FOR SAFETY:** When servicing machine, wear appropriate personal protection equipment as needed. Avoid contact with battery acid.

2. Using an approved lift strap that supports the weight of battery pack, connect the strap to the two lift brackets as shown. Using a lift hoist rated to handle the weight of the battery pack, carefully lift the battery packs to and from machine. Keep one hand on the battery lift-out tray when lifting for stability (Figure 4).

## OPERATION

---

Before lifting battery pack, make sure the batteries are secured to the battery lift-out tray with the supplied battery strap as shown (Figure 4).



FIG. 4

3. Reconnect the battery cable connection after installing battery pack.

---

## HOW THE MACHINE WORKS

---

### Conventional scrubbing:

When using the conventional scrubbing mode, water and detergent mixture from the solution tank flows to the floor and the rotating brush(es)/pad(s) scrub the floor clean. As the machine moves forward, the squeegee with vacuum suction picks up the dirty solution from the floor into the recovery tank.

### ec-H<sub>2</sub>O NanoClean Technology (option):

When using the ec-H<sub>2</sub>O NanoClean technology, normal water passes through a module where it is electrically converted into a cleaning solution. The electrically converted water attacks the dirt, allowing the machine to easily scrub away the suspended soil. The converted water then returns to normal water in the recovery tank.

---

## BRUSH AND PAD INFORMATION

---

For best cleaning results use the appropriate brush or pad for your cleaning application. Listed below are brushes and pads and the applications for which each is best suited.

*NOTE: The amount and type of soilage play an important role in determining the type of brush or pad to use. Contact a Tennant representative for specific recommendations.*

### Soft nylon bristle scrub brush (White) -

Recommended for cleaning coated floors without removing finish. Cleans without scuffing.

### Polypropylene bristle scrub brush (Black) -

This general purpose polypropylene bristle scrub brush is used for scrubbing lightly compacted soilage. This brush works well for maintaining concrete, wood and grouted tile floors.

### Super abrasive bristle scrub brush (Gray) -

Nylon fiber impregnated with abrasive grit to remove stains and soilage. Strong action on any surface. Performs well on buildup, grease, or tire marks.

### Polishing pad (White) -

Used to maintain highly polished or burnished floors.

**Buffing pad (Red) -** Used for light duty scrubbing without removing floor finish.

**Scrubbing pad (Blue) -** Used for medium to heavy-duty scrubbing. Removes dirt, spills, and scuffs and leaves surface clean ready for recoating.

**Stripping pad (Brown) -** Used for stripping of floor finish to prepare the floor for recoating.

**Heavy duty stripping pad (Black) -** Used for aggressive stripping of heavy finishes/sealers, or very heavy duty scrubbing.

**Surface preparation pad (Maroon) -** Used for very aggressive chemical free removal of floor finish to prepare the floor for re-coating

## MACHINE SETUP

### CHARGE BATTERIES

Lithium-ion batteries must be charged prior to initial use, see CHARGING BATTERIES.

### ATTACHING SQUEEGEE ASSEMBLY

**FOR SAFETY: Before leaving or servicing machine, stop on level surface, turn off machine, remove key and set parking brake if equipped.**

1. Lift the squeegee mount bracket to the raised position. Place toe under pedal to lift (Figure 5).



FIG. 5

2. Mount the squeegee assembly to the squeegee mount bracket (Figure 6). Tighten knobs to secure squeegee assembly to bracket.

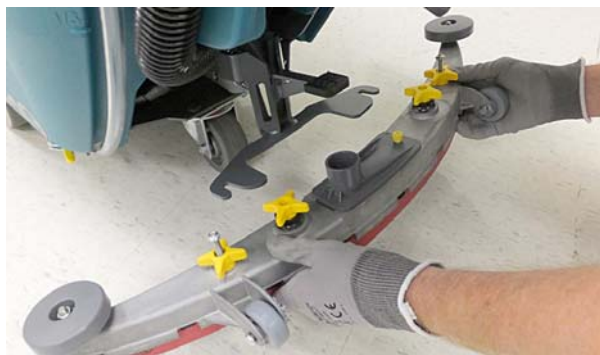

FIG. 6

3. Connect the vacuum hose to the squeegee assembly (Figure 7).

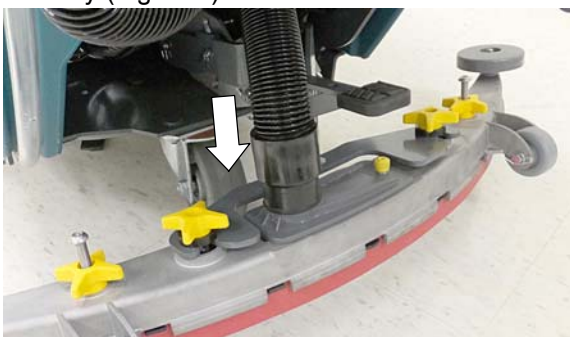

FIG. 7

### INSTALLING BRUSH/PAD - 3 Lug Disk

**FOR SAFETY: Before leaving or servicing machine, stop on level surface, turn off machine, remove key and set parking brake if equipped.**

1. Step down on the scrub head lift pedal to raise the scrub head off the floor (Figure 8).



FIG. 8

2. Attach the pad to the pad driver before installing the disk (Figure 9). Secure pad with centerlock.

**FOR SAFETY: Do not operate machine with pads or accessories not supplied or approved by Tennant. The use of other pads may impair safety.**

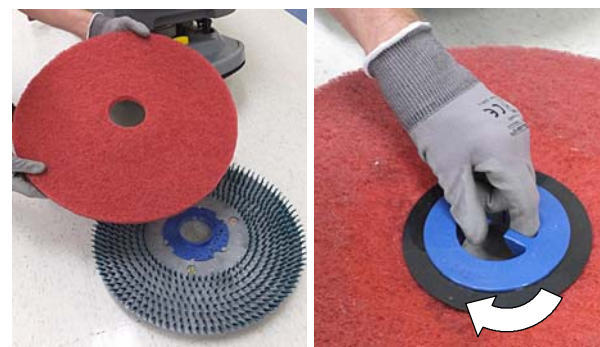

FIG. 9

3. Single disk model - Position the three lugs into the motor hub slots and give the pad driver/brush a quick counter-clockwise turn to engage hub (Figure 10). View through the scrub head window to align lugs.



FIG. 10

## OPERATION

Dual disk model - Turn the brush motor hub until the lug slot with spring clip is visible. Position the three lugs into the motor hub slots and give the pad driver/brush a quick turn towards the spring clip (Figure 11). View through the scrub head window to align lugs.

**NOTE:** The left and right disks engage the hubs in opposite directions.

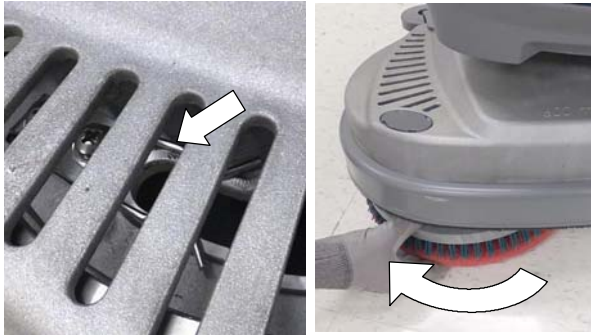

FIG. 11

4. Single disk model - To remove the pad driver/brush, grip the disk and give it a quick turn in the direction as shown (Figure 12).



FIG. 12

Dual disk model - To remove the pad driver/brush, grip the disk and give it a quick turn in the direction as shown (Figure 13).

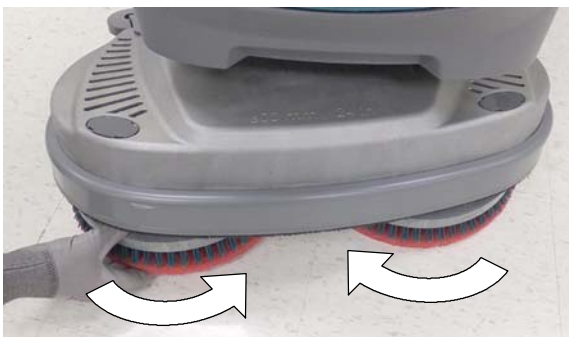

FIG. 13

## INSTALLING BRUSH/PAD - Insta-Click Magnetic Disk (Option)

**FOR SAFETY:** Before leaving or servicing machine, stop on level surface, turn off machine, remove key and set parking brake if equipped.

**⚠ WARNING:** Magnetic Field Hazard. Magnetic pad driver/brush can be harmful to pacemaker wearers or medical implants.

1. Step down on the scrub head lift pedal to raise the scrub head off the floor (Figure 14).



FIG. 14

2. Attach the pad to the pad driver before installing the driver (Figure 15). Secure pad with centerlock.

**FOR SAFETY:** Do not operate machine with pads or accessories not supplied or approved by Tennant. The use of other pads may impair safety.

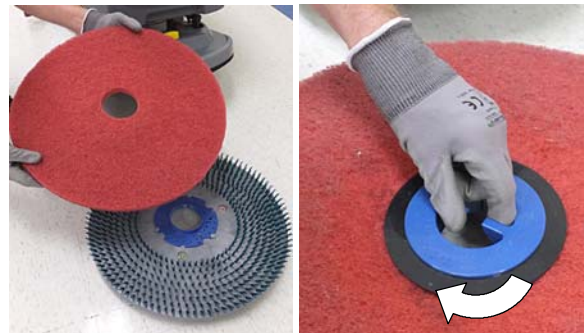

FIG. 15

3. Place the pad driver/brush under the scrub head and lift into position. The Insta-Click pad driver/brush will automatically click into position (Figure 16).



FIG. 16

- To remove the pad driver(s)/brush(es), raise the scrub head and press the yellow plunger button with foot or hand (Figure 17). Pad will drop to floor.

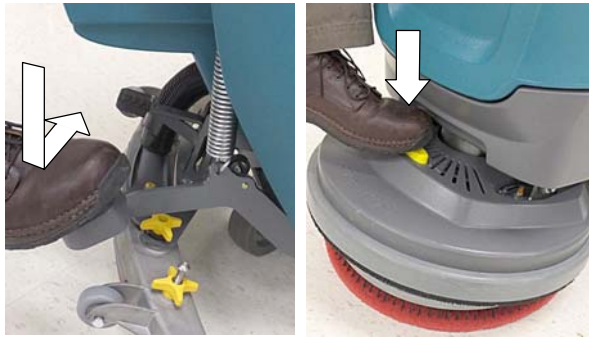

**FIG. 17**

**INSTALLING PAD - Orbital**

For best cleaning performance and to avoid damaging the pad driver plate or floor surface, always use backer pad with work pads (Figure 18).

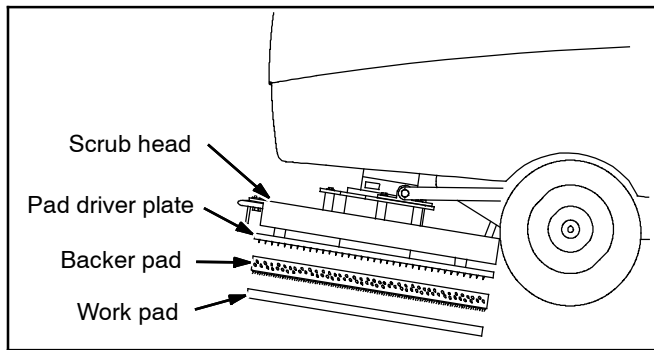

**FIG. 18**

**FOR SAFETY: Before leaving or servicing machine, stop on level surface, turn off machine, remove key and set parking brake if equipped.**

- Step down on the scrub head lift pedal to raise the scrub head off the floor (Figure 19).



**FIG. 19**

- Install the backer pad, retaining strips facing outward, to bottom of scrub head (Figure 20). Make sure pad is centered on scrub head.



**FIG. 20**

- Attach the work pad to the backer pad (Figure 21).



**FIG. 21**

**INSTALLING CYLINDRICAL BRUSHES**

**FOR SAFETY: Before leaving or servicing machine, stop on level surface, turn off machine, remove key and set parking brake if equipped.**

- Step down on the scrub head lift pedal to raise the scrub head off the floor (Figure 22).



**FIG. 22**

## OPERATION

2. Remove the debris tray by sliding it out from the scrub head (Figure 23).

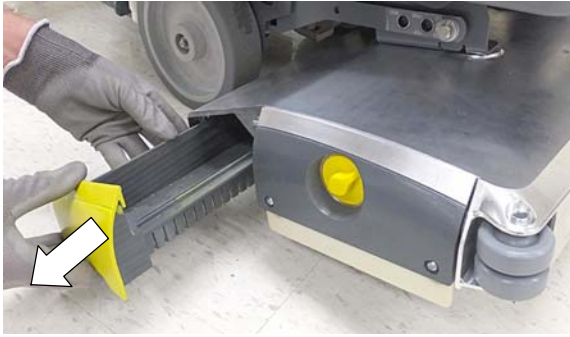

FIG. 23

3. Remove the idler plate from the scrub head by unscrewing the yellow knob (Figure 24).



FIG. 24

4. Slide the brushes into the scrub head and connect the slotted ends of each brush into the drive hubs (Figure 25).

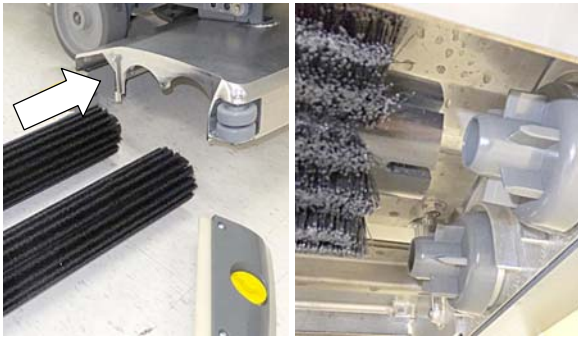

FIG. 25

5. Connect the idler plate to the brush ends and reattach the idler plate. Make sure the idler plate hooks are engaged before tightening knob (Figure 26).



FIG. 26

6. Replace debris tray.

## FILLING SOLUTION TANK

**FOR SAFETY: Before leaving or servicing machine, stop on level surface, turn off machine, remove key and set parking brake if equipped.**

Remove the solution tank lid and fill the solution tank. Stop filling tank when the level reaches the "3/3" mark on the solution tank drain hose indicator (Figure 27).

**ec-H<sub>2</sub>O Scrubbing** - Fill solution tank with only cool clean water (less than 70°F/21°C). Do not add conventional floor cleaning detergents. An ec- H<sub>2</sub>O system fault will occur if cleaning detergents are added.

**Conventional Scrubbing** - Fill solution tank with water (not to exceed 60°C/140°F). Pour a recommended cleaning detergent into the solution tank according to mixing instructions on the container.

*NOTE: Do not use the ec-H<sub>2</sub>O system when there are conventional cleaning detergents in the solution tank. Drain, rinse, and refill the solution tank with clear cool water before operating the ec-H<sub>2</sub>O system. Conventional cleaning detergents will cause an ec- H<sub>2</sub>O system fault.*

**⚠ WARNING: Flammable materials can cause an explosion or fire. Do not use flammable materials in tank(s).**

**ATTENTION:** For Conventional Scrubbing, only use commercially approved cleaning detergents. Machine damage due to improper detergent usage will void the manufacturer's warranty.



FIG. 27

The solution tank fill- port is equipped with two hose clips to hold hose while filling. The two clips are different hose diameter sizes (Figure 28).

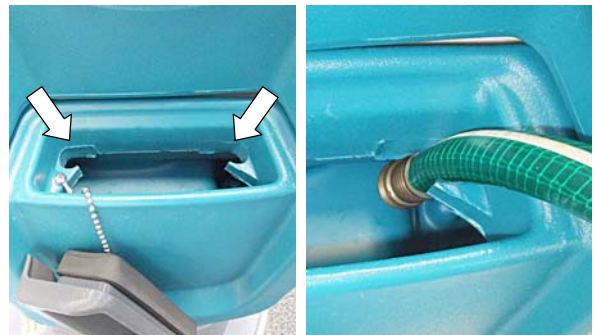

FIG. 28

**ec-H2O NanoClean WATER CONDITIONING CARTRIDGE (ec-H2O model)**

The ec-H2O system is equipped with a water conditioning cartridge (Figure 29). The cartridge is designed to protect the machine’s plumbing system from potential scaling.

The cartridge is required to be replaced when it reaches its maximum water usage or expiration time of when the cartridge was activated, whichever ever comes first.

Depending on machine usage a new cartridge can last anywhere from 12 to 24 months.

The control panel will signal a code when it’s time to replace cartridge. See SERVICE INDICATOR CODES for further details.



FIG. 29

All cartridges are labeled with a manufacture date. The shelf-life of an un-installed cartridge is one year from manufacture date. For new cartridge replacement, the ecH2O module timer must be reset. See ec-H2O NanoClean WATER CONDITIONING CARTRIDGE REPLACEMENT.

**ATTENTION:** During first time use and after replacing the water conditioning cartridge, the ec-H2O system will automatically override the selected solution flow rate for up to 75 minutes.

**ACCESSORY RAIL**

The machine is equipped with an accessory rail which also serves as the recovery tank and solution tank drain hose holder.

The accessory rail is designed to store the squeegee assembly and other accessory items (Figure 30).

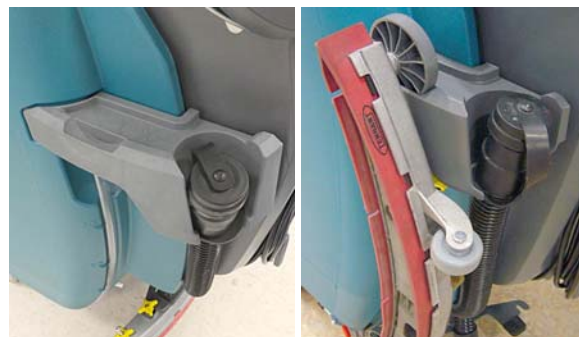

FIG. 30

A debris bag hook is located on the left side of the control console (Figure 31).



FIG. 31



**ATTENTION:** Do not use the accessory rails to lift machine, damage may occur.



**ATTENTION:** Do not step on accessory rails, damage may occur.

# OPERATION

## MACHINE OPERATION

**FOR SAFETY: Do not operate machine unless operator manual is read and understood.**

### PRE-OPERATION CHECK LIST

- Sweep area and remove any obstructions.
- Check brushes/pads for wear and damage.
- Check squeegee blades for wear and damage.
- Confirm recovery tank empty and screen and debris tray is clean.
- Check scrub head skirt for wear and damage.
- Cylindrical brush model - confirm scrub head debris tray is empty and clean.
- ec-H2O Scrubbing: Confirm solution tank is filled with clear cool water only.
- ec-H2O Scrubbing: Ensure all conventional cleaning agents/restorers are drained and rinsed from solution tank.
- Check machine for proper operation.

### OPERATING MACHINE

1. Release the parking brake lever, if equipped (Figure 32)
2. Turn the key to the on ( I ) position (Figure 32).

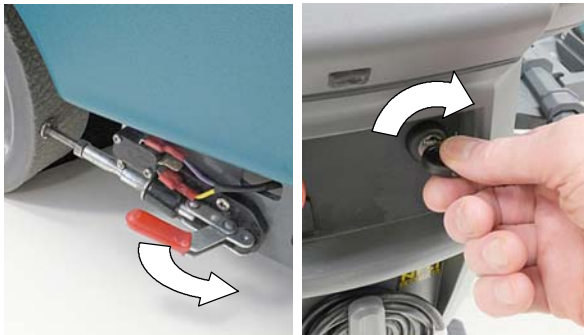

FIG. 32

3. ec- H2O Models: The ec-H2O system automatically turns on at each key start. A blue ec-H2O indicator appears when machine is equipped with the ec-H2O option. The green LED illuminates when ec-H2O is activated. To turn off the ec-H2O system, press the ec-H2O button. The green LED indicator will disappear (Figure 33).

**ATTENTION:** During first time use and after replacing the water conditioning cartridge, the ec-H2O system will automatically override the selected solution flow rate for up to 75 minutes.

**ATTENTION:** If cleaning detergent is accidentally cycled through ec-H2O system, immediately turn the ec-H2O system off. Drain solution tank, refill with cool water and operate the ec-H2O system to flush out detergent.



FIG. 33

ec-H2O INDICATOR	CONDITION
Solid blue	Normal operation
Blinking blue/red	Water conditioning cartridge expired. Replace cartridge.
Solid or blinking red	See Service Indicator Codes.

4. Lower the scrub head to the floor by stepping on the scrub head lift pedal as shown (Figure 34).



FIG. 34

5. Lower the squeegee assembly to floor by stepping on foot pad as shown (Figure 35). To raise squeegee assembly, place toe under foot pad and lift. The vacuum motor will start when squeegee assembly is lowered.

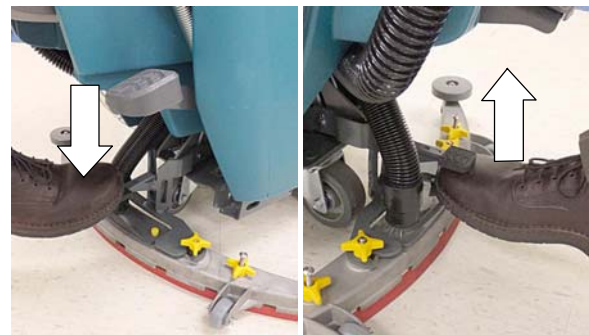

FIG. 35

6. Drive models - push the directional lever to the forward position to go forward (Figure 36). To reverse the machine pull the directional lever backwards.



FIG. 36

7. To begin scrubbing, pull the start bail (Figure 37).



FIG. 37

8. Drive models - Adjust the scrubbing speed by turning the speed dial to the desired speed (Figure 38).

Push models - Slowly push the machine forward. The rotating brush(es) will help assist the machine forward.



FIG. 38

9. ec-H<sub>2</sub>O model: To adjust the solution flow rate when ec-H<sub>2</sub>O scrubbing, press the solution flow button located on the ec-H<sub>2</sub>O module (Figure 39). One LED= low, two LED's=medium, and three LED's= high.

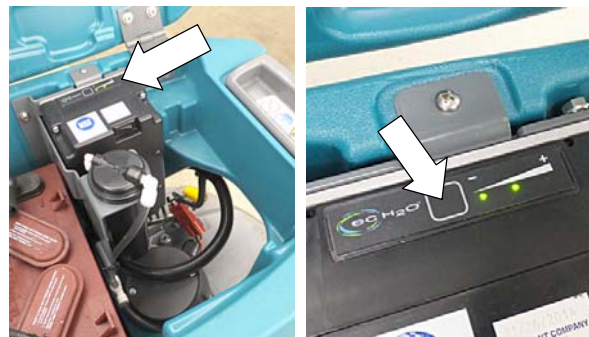

FIG. 39

10. To adjust the solution flow rate when conventional scrubbing, turn the solution flow control knob located underneath machine (Figure 40).

*NOTE: The solution flow control knob is only functional when conventional scrubbing.*

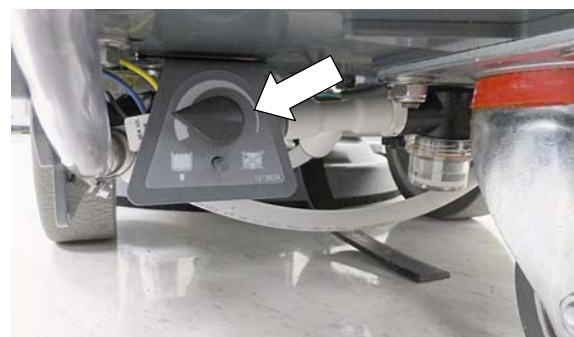

FIG. 40

11. T300e model option - When extra brush pressure is needed for heavily soiled areas lift the down pressure lever (Figure 41).

*NOTE: Release the down pressure lever when raising scrub head.*



FIG. 41

12. To stop scrubbing, release the start bail and raise the scrub head and squeegee assembly off floor. Turn key off and set parking brake, if equipped.

## OPERATION

### WHILE OPERATING MACHINE

**⚠ WARNING: Flammable materials materials or reactive metals can cause an explosion or fire. Do not pick up.**

1. Overlap each scrub path by 2 inches (5 cm).
2. Keep machine moving to prevent damage to floor finish.
3. Wipe squeegee blades with a cloth if blades leave streaks.
4. Avoid bumping the machine into posts and walls.

**FOR SAFETY: When operating machine, do not scrub on inclines that exceed 9% grade or transport on inclines that exceed 21% grade.**

5. Pour a recommended foam control solution into the recovery tank if excessive foam appears.

**ATTENTION:** Foam buildup will not activate the float shut-off screen, vacuum motor damage will result.

6. Use the double scrubbing method for heavily soiled areas. First scrub the area with the squeegee up, let solution set for 3-5 minutes, then scrub the area a second time with squeegee down.
7. Orbital Scrub Head Model - Use caution when working near the tile cove (Figure 42) and floor mounted fixtures such as pedestal sinks and other breakable items. Keep the metal scrub head edge away to avoid possible damage.

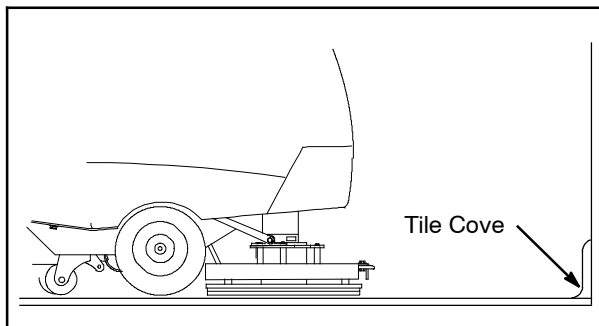

FIG. 42

8. When leaving the machine unattended, remove the key and set the parking brake, if equipped.
9. Do not operate machine in areas where the ambient temperature is above 110°F/43°C or below freezing 32°F/0°C.

### EMERGENCY SHUT-OFF BUTTON (Drive models)

Push the emergency shut-off button in the event of an emergency (Figure 43). This red button shuts off all power to machine. To regain power, turn the button clockwise and restart the key.

Only use this button in the event of an emergency. It is not intended for routine machine shutdown.



FIG. 43

### BATTERY DISCHARGE INDICATOR

The battery discharge indicator (BDI) displays the charge level of the batteries while the machine is operating. When the batteries are fully charged, all five indicators are lit (Figure 44). When the discharge level reaches the red light, stop scrubbing and recharge the batteries. If the red light begins to flash, the scrubbing function will automatically shut off to protect the batteries from total discharge. Drive Model: The machine will still propel when the red light is flashing, this will allow user to transport machine to charging station.

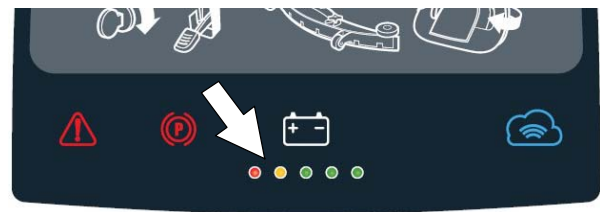

FIG. 44

**CIRCUIT BREAKER PANEL**

The machine is equipped with resettable circuit breakers to protect the machine from a current overload. If a circuit breaker trips, disconnect the battery cable connection and reset the breaker by pressing the reset button after the breaker has cooled down. Reconnect the battery cable connection. If the circuit breaker does not reset or continues to trip contact service personnel.

The circuit breaker panel is located near the battery compartment and identified as described below (Figure 45).

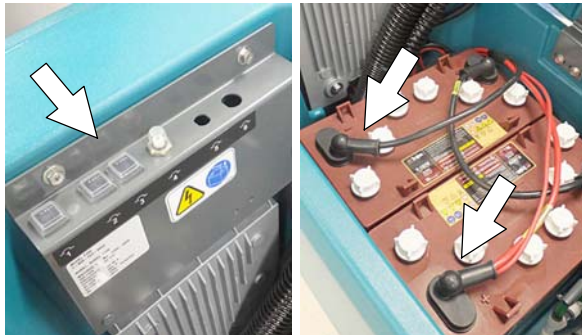

FIG. 45

Circuit Breaker	Rating	Circuit protected
CB1	4 A	Key switch, control board
CB2	4 A	ec-H2O module
CB3	4 A	ec-H2O pump
CB4	30 A	Propel
CB5	37 A	Brush motor
CB6	20 A	Vacuum motor

**FOR SAFETY: When servicing machine, all repairs must be performed by trained personnel.**

The circuit breaker panel is protected by a splash guard. To access the circuit breaker panel when the recovery tank is in the down position lift the splash guard as shown (Figure 46).



FIG. 46

**HOUR METER**

The hour meter records the number of hours the machine has been operated. Use the hour meter to perform specific maintenance procedures and to record service history (Figure 47).



FIG. 47

# OPERATION

## DRAINING TANKS

**FOR SAFETY:** Before leaving or servicing machine, stop on level surface, turn off machine, remove key and set parking brake if equipped.

### DRAINING RECOVERY TANK

Drain and clean the recovery tank daily and between solution tank refills.

1. Transport the machine to drain area.
2. For models equipped with drain hose caps, hold the hose upward, remove cap then slowly lower hose to drain. For models equipped with flow control valve drain hose, lower hose and slowly open valve to drain (Figure 48).



FIG. 48

**NOTE:** When using a bucket to drain the machine, do not use the same bucket to fill the solution tank.

3. Remove and clean the float shut-off screen (Figure 49).



FIG. 49

4. Remove the debris tray and empty (Figure 50).



FIG. 50

5. Rinse out the recovery tank with clean water and wipe clean of any soil residue (Figure 51).

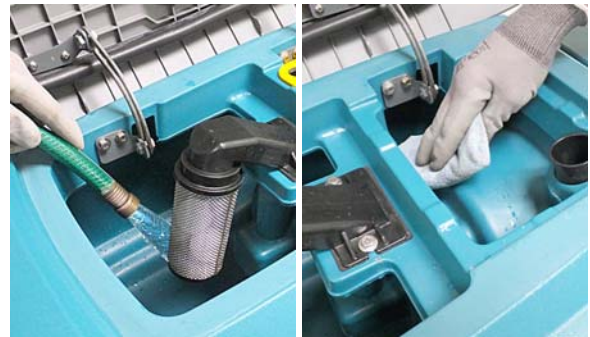

FIG. 51

### DRAINING SOLUTION TANK

Drain the solution tank daily.

1. Transport the machine to drain area.

**FOR SAFETY:** Before leaving or servicing machine, stop on level surface, turn off machine, remove key and set parking brake if equipped.

2. To drain remaining water from solution tank, pull the solution hose from the accessory rail (Figure 52).



FIG. 52

Firmly reconnect the solution hose to accessory rail after draining tank.

- Rinse out solution tank with clean water (Figure 53).



**FIG. 53**

- Remove the solution tank filter and clean screen after every 50 hours of use (Figure 54). Solution filter is located under machine at rear. Drain solution tank before removing filter.

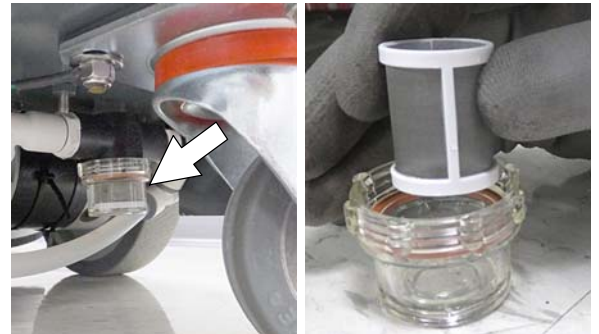
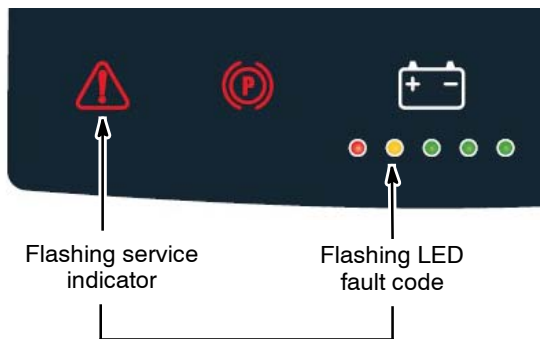

**FIG. 54**

## SERVICE INDICATOR CODES

When the machine or battery charger detects a fault, the service indicator will flash. A fault code will be provided to determine problem as described below.

### T300e Control Panel



LED Fault Code * = Flashing	CAUSE	SOLUTION
* * * * *	Emergency stop button activated.	Release emergency stop button and restart machine.
. . . * *	Brush motor wiring, connector or control board problem.	Contact service.
. . * . .	Vacuum motor wiring, connector or control board problem.	Contact service.
. . * * .	Propel circuit breaker tripped.	Disconnect battery and reset circuit breaker. If trip repeats, contact service.
. * . * *	Software load failure.	Contact service.
* . . . *	Propel I-Drive fault Propel I-Drive communication lost	Restart machine. If fault repeats, contact service.
* . . * .	Propel motor shorted fault	Contact service.
* . . * *	Brush motor over current	Contact service.

## OPERATION

### SERVICE INDICATOR CODES - Continued

LED Fault Code * = Flashing	CAUSE	SOLUTION
* • * • *	Start bail is pulled or obstructed before turning machine on.	Release start bail or remove bail obstruction before turning machine on.
* • * * •	Brush motor control board fault Vacuum motor control board fault	Disconnect battery cable connection and contact service to replace control board.
* • * * *	Vacuum motor over current.	Contact service.
* * • • •	Vacuum motor shorted fault.	Contact service.
* * * • *	Brush motor shorted fault.	Contact service.
• * * * •	Charger communication fault Scrub control board comm. fault ec-H2O system comm. fault	Restart. If fault code persists, contact service.

### ON-BOARD BATTERY CHARGER SERVICE INDICATOR CODES

LED Fault Code * = Flashing	CAUSE	SOLUTION
* * * • •	Charger error condition.	Contact service.
• * * • •	Charger is not connected to battery pack.	Check cable connections.
• * • • •	Charger overheated.	Let charger cool. Move to well ventilated area. Charge batteries in areas with temperatures 80°F/27°C or less. If fault persists, contact service.
• * * * •	Charger communication fault	Restart charger. If fault code persists, contact service.
• * * • *	Charger timer exceeded maximum charging time. Interrupts charging cycle.	Replace Batteries.

ec-H2O SYSTEM SERVICE INDICATOR CODES - OPTION

T300e Control Panel

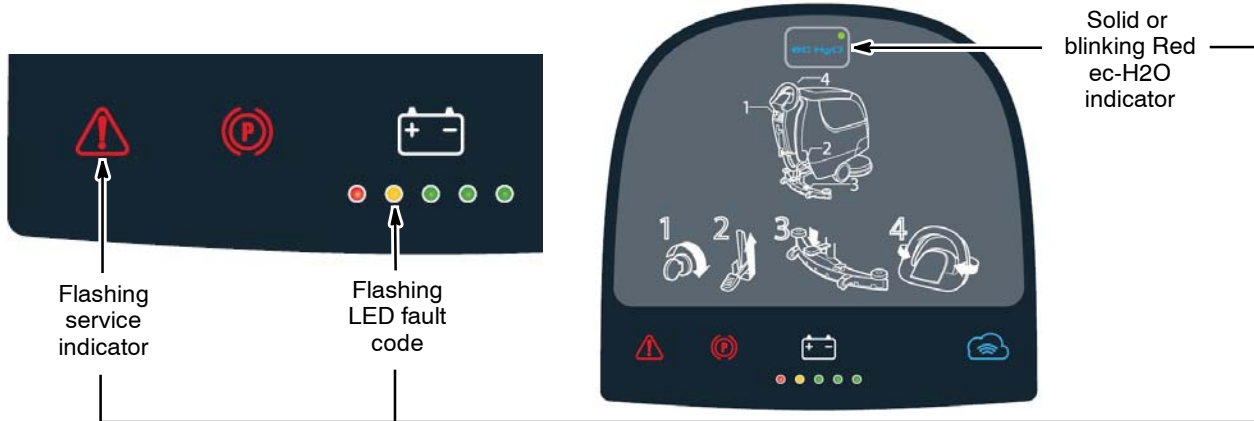

LED Fault Code * = Flashing	CAUSE	SOLUTION
• * * * •	ec-H2O system communication fault.	Restart. If fault code persists, contact service.
• * • * •	ec-H2O pump wiring, connector or control board problem.	Contact service.
• * * * *	ec-H2O pump over current	Contact service.
* • • • •	ec-H2O pump shorted fault	Contact service.
* • * • •	ec-H2O circuit breaker tripped	Reset circuit breaker. If trip repeats, contact service.
ecH2O indicator solid red	ec-H2O electrical faults	Contact service.
ecH2O indicator blinking red*	ec-H2O water and plumbing faults	Contact service.
ecH2O indicator blinking blue/red	Water conditioning cartridge expired	Replace water conditioning cartridge.

\*Verify if cleaning detergent was added to solution tank. If ec-H2O system was operated with cleaning detergent, drain solution tank, add clear water and operate the ec-H2O system until the fault code clears.

# MAINTENANCE

## MAINTENANCE CHART

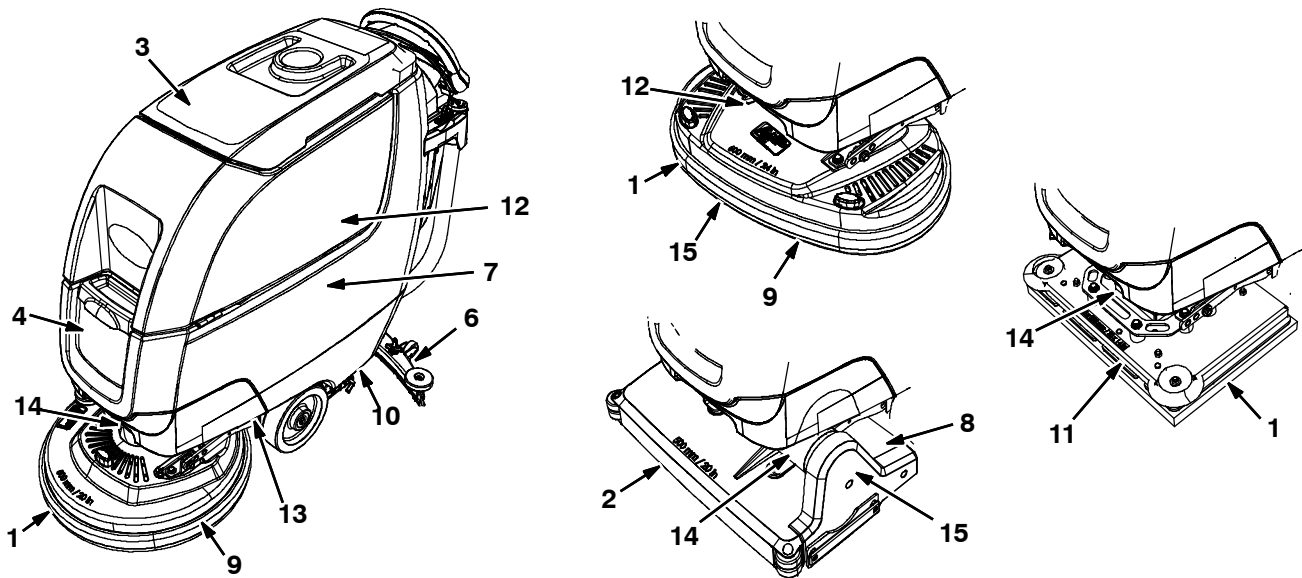

Interval	Person Resp.	Key	Description	Procedure
Daily	O	1	Pad(s)	Check, flip or replace
	O	1	Brush(es)	Check, clean
	O	2	Cylindrical Brushes	Check, clean
	O	3	Recovery tank	Drain, rinse, clean float shut-off screen and debris tray if equipped
	O	4	Solution tank	Drain, rinse
	O	6	Squeegee	Clean, check for damage and wear
	O	7	Batteries	Charge if necessary
	O	8	Debris trough	Clean
	O	9	Scrub head skirt	Check for damage and wear
Weekly	O	7	Battery cells	Check electrolyte level
	O	6	Squeegee assembly drip trap reservoir	Check, clean
50 Hours	O	2	Cylindrical brushes.	Rotate brushes. Check for wear
	O	2	Cylindrical scrub head	Clean underside of scrub head
	O	3	Recovery tank lid seal	Check for wear.
	O	10	Solution tank filter	Clean
100 Hours	O	7	Battery watering system (option)	Check hoses for damage and wear
200 Hours	O	7	Batteries, terminals and cables	Check and clean
500 Hours	T	11	Lower orbital isolators	Replace (4 qty)
750 Hours	T	12	Vacuum motor	Replace carbon brushes
1250 Hours	T	13	Propel motor	Replace carbon brushes
	T	14	Brush motor	Replace carbon brushes
	T	15	Brush belt	Replace belt

O = Operator T = Trained Personnel

**MACHINE MAINTENANCE**

To keep the machine in good working condition, simply perform the following maintenance procedures.

**FOR SAFETY:** Before leaving or servicing machine, stop on level surface, turn off machine, remove key and set parking brake if equipped.

**FOR SAFETY:** When servicing machine wear personal protection equipment as needed. All repairs must be performed by trained personnel

**AFTER DAILY USE**

1. Drain and rinse out the recovery tank (Figure 55). See DRAINING TANKS.



FIG. 55

2. Remove the debris tray and empty (Figure 56).



FIG. 56

3. Remove and clean the float shut-off screen (Figure 57).



FIG. 57

4. Drain and rinse out the solution tank (Figure 58).



FIG. 58

5. Disk scrub head - Turn pad over or replace when worn (Figure 59).

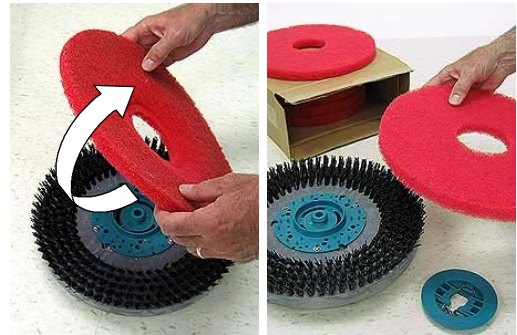

FIG. 59

Orbital scrub head - Turn the work pad over or replace when worn (Figure 60).



FIG. 60

6. Insta-Click pad driver/brushes - clean any debris buildup from hub connection area (Figure 61).



FIG. 61

# MAINTENANCE

7. Wipe the squeegee blades clean. Inspect blades for wear and damage (Figure 62). Rotate blade if worn. See SQUEEGEE BLADE REPLACEMENT.



FIG. 62

8. Check the scrub head skirt for wear or damage (Figure 63). Replace if worn or damaged.



FIG. 63

9. Clean the outside surface of the machine with an all purpose cleaner and damp cloth (Figure 64).



FIG. 64

10. Cylindrical scrub head - Remove and clean debris trough (Figure 65).



FIG. 65

11. Charge batteries (Figure 66). See BATTERIES.



FIG. 66

## AFTER WEEKLY USE

1. Check the electrolyte level in all batteries (Figure 67). See BATTERIES.

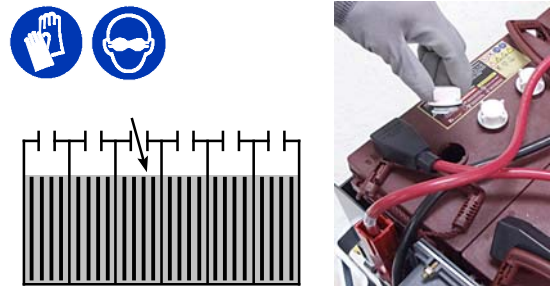

FIG. 67

2. Remove the drip trap cover from the squeegee assembly and clean reservoir (Figure 68).



FIG. 68

**AFTER EVERY 50 HOURS OF USE**

1. Remove the solution tank filter and clean screen (Figure 69). Turn the filter bowl counter-clockwise to remove. Make sure to drain solution tank before removing filter.

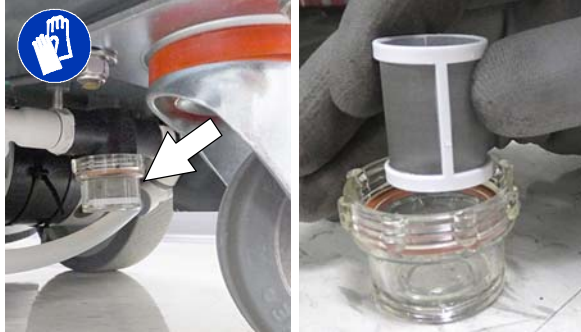

**FIG. 69**

2. Cylindrical brushes - Rotate brushes from front to rear (Figure 70). Replace brushes when they no longer clean effectively.



**FIG. 70**

3. Cylindrical scrub head - Remove debris buildup from underside of scrub head (Figure 71).



**FIG. 71**

4. Inspect and clean the seal on the recovery tank lid (Figure 72). Replace seal if damaged.

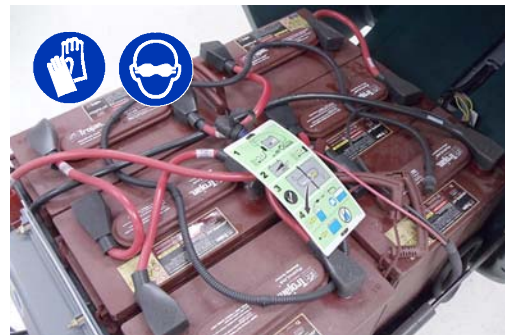

**FIG. 72**

**AFTER EVERY 100 HOURS OF USE**

If machine is equipped with the optional battery watering system, check the watering hoses and connections for damage and wear (Figure 73). Replace system if damaged.

**FOR SAFETY: When servicing batteries, wear personal protection equipment as needed. Avoid contact with battery acid.**



**FIG. 73**

**ELECTRIC MOTORS**

Replace motor carbon brushes as indicated. Contact trained personnel for carbon brush replacement.

<b>Carbon Brush Replacement</b>	<b>Hours</b>
Vacuum motor	750
Propel motor (drive model)	1250
Disk brush motor	1250
Cylindrical brush motor	1250
Orbital brush motor	1250

## MAINTENANCE

---

### BELTS

**FOR SAFETY:** Before leaving or servicing machine, stop on level surface, turn off machine, remove key and set parking brake if equipped.

Replace belts every 1250 hours. Contact trained personnel for belt replacement (Figure 74).

#### Cylindrical Brush Drive Belt

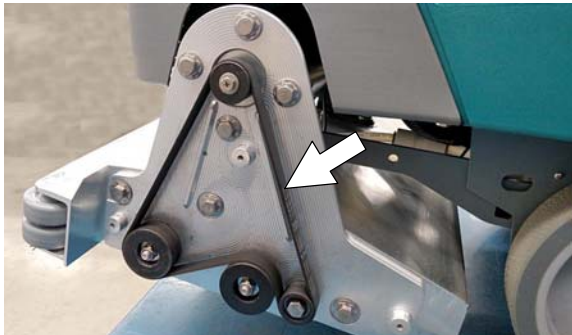

#### Dual Disk Brush Drive Belt

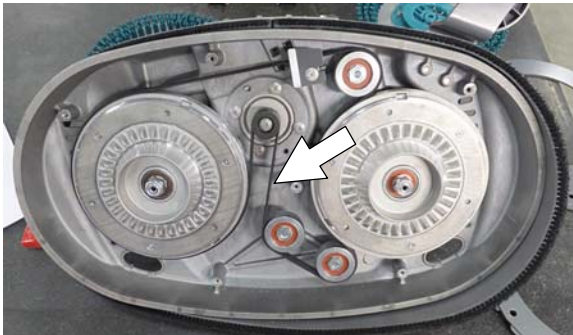

FIG. 74

---

### ORBITAL SCRUB HEAD ISOLATORS

**FOR SAFETY:** Before leaving or servicing machine, stop on level surface, turn off machine, remove key and set parking brake if equipped.

Replace the four lower vibration isolators every 500 hours. The lower isolators (hidden) are located between the deck plate the driver plate. Contact trained personnel for isolator replacement (Figure 75).



FIG. 75

---

### BATTERIES

**FOR SAFETY:** Before servicing machine, stop on level surface, turn off machine and remove key.

Your machine is equipped with either flooded (wet) lead-acid, maintenance-free (Sealed AGM) batteries or lithium-ion battery supplied by Tennant.

---

#### FLOODED (WET) AND MAINTENANCE-FREE SEALED LEAD-ACID BATTERIES

The lifetime of the batteries depends on their proper maintenance. To get the most life from the batteries;

- Do not charge the batteries more than once a day and only after running the machine for a minimum of 15 minutes.
- Do not leave the batteries partially discharged for long period of time.
- Only charge the batteries in a well-ventilated area to prevent gas build up. Charge batteries in areas with ambient temperatures 80°F / 27°C or less.
- Allow the charger to complete charging the batteries before re-using the machine.
- Maintain the proper electrolyte levels of flooded (wet) batteries by checking levels weekly.

Your machine is equipped with either flooded (wet) lead-acid or maintenance-free batteries supplied by Tennant.

**FOR SAFETY:** When servicing machine, keep all metal objects off batteries. Avoid contact with battery acid.

Maintenance-free (Sealed AGM) batteries do not require watering. Cleaning and other routine maintenance is still required.

The flooded (wet) lead-acid batteries require routine watering as described below. Check the battery electrolyte level weekly.

**NOTE:** ***Do Not** check the electrolyte level if the machine is equipped with the optional battery watering system. Proceed to the BATTERY WATERING SYSTEM.*

The electrolyte level should be slightly above the battery plates as shown before charging (Figure 76). Add distilled water if low. **DO NOT OVERFILL.** The electrolyte will expand and may overflow when charging. After charging, distilled water can be added up to about 3 mm (0.12 in) below the sight tubes.

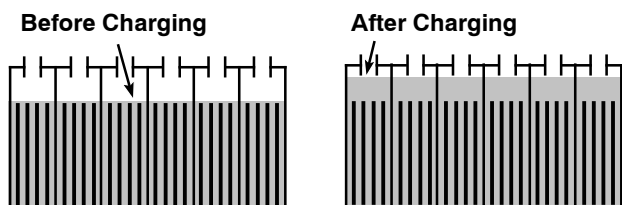
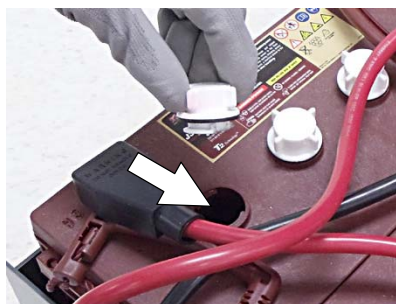

FIG. 76

*NOTE: Make sure the battery caps are in place while charging. There may be a sulfur smell after charging batteries. This is normal.*

### CHECKING CONNECTIONS / CLEANING

After every 200 hours of use, check for loose battery connections and clean the surface of the batteries, including terminals and cable clamps to prevent battery corrosion. Use a scrub brush with a strong mixture of baking soda and water (Figure 77). Do not remove battery caps when cleaning batteries.



FIG. 77

### LITHIUM-ION BATTERY

The lithium-ion battery pack is a maintenance-free battery protected by a battery management system (BMS). To achieve the maximum battery life, carefully follow the instructions below:

- Lithium-Ion batteries must be charged prior to initial use.
- Carefully follow the Important Safety Instructions section in the manual when using the Lithium-ion Battery Model.
- Only use the lithium-ion battery charger supplied with machine.
- Charge battery pack in well-ventilated areas. For best charging performance, charge the battery pack in temperatures below 80°F/27°C and above 32°F/0°C. Battery pack may shut down and not take a charge in elevated or freezing temperatures.
- Do not store the machine for an extended period if battery is discharged to the last bar, the battery may further discharge to a level that is unrecoverable.
- When the machine shuts down due to a depleted battery pack, do not repeatedly cycle the key on and off. This may cause permanent battery pack damage. Recharge battery pack immediately to avoid damage.
- Opportunity charging (i.e. partial charge cycle of a half hour or more) is only recommended if discharge level is below 80%.
- Do not operate machine in temperatures above 104°F / 40°C or below -4°F / -20°C. Machine may shutdown if exceed these temperatures.
- Contact Tennant Service for lithium-ion battery service and replacement.

## MAINTENANCE

### BATTERY POWER BUTTON / BATTERY DISCHARGE INDICATOR

Each Lithium-Ion battery contains a power button to turn on/off the battery power supply. The battery discharge indicator (BDI) displays the current state of the battery (Figure 78).



FIG. 78

To display the battery charge status or fault state (while the batteries are active), press and hold the power button of any battery for one second. When the batteries are fully charged, all five green indicators are lit. As the battery discharges, the indicator levels decreases. If the indicators flash red the battery is getting very low. If the indicators display solid red along with green, the battery has a fault. Contact Tennant Service to fix the fault.

LED Indicator Status	Battery State of Charge
	81- 100%
	61- 80%
	41- 60%
	21- 40%
	11- 20%
	1- 10%
	Fault - Contact Service

To turn off the battery power (while the batteries are active), press and hold the battery power button of any battery for **20 seconds**. The battery discharge indicators will turn off. Turning off one battery will shut down power to all connected batteries. Batteries should be shut down before any service is completed on the battery modules.

To turn on the battery power (when the batteries are shutdown), press and hold the power button on each battery for **5 seconds**. The battery discharge green indicators will illuminate when turned on.

### CHARGING BATTERIES

The charging instructions in this manual are intended for the battery charger supplied with your machine. The use of other battery chargers that are not supplied and approved by Tennant are prohibited.

If your machine is equipped with an off-board battery charger refer to the charger's owners manual for operating instructions. Contact distributor or Tennant for battery charger recommendations if machine is not equipped with charger.

**FOR SAFETY: The use of incompatible battery chargers may damage battery packs and potentially cause a fire hazard.**

**IMPORTANT NOTICE:** The battery charger is set to charge the battery type supplied with your machine. If you choose to change to a different battery type or capacity (i.e. flooded (wet) lead-acid, maintenance-free, sealed, AGM batteries, etc.), the charger's charging profile must be changed to prevent battery damage. See BATTERY CHARGER SETTINGS.

1. Transport the machine to a well-ventilated area.

**⚠ WARNING: Batteries emit hydrogen gas. Explosion or fire can result. Keep sparks and open flame away when charging.**

2. Park the machine on a flat, dry surface, turn off machine and remove key.

**FOR SAFETY: When servicing batteries, stop on level surface, turn off machine, remove key and set parking brake if equipped.**

3. If the machine is equipped with flooded (wet) lead-acid batteries check the battery electrolyte level weekly before charging. See *FLOODED (WET) LEAD-ACID BATTERIES*.
4. For models equipped with on-board chargers, remove the charger's power cord from the storage hooks and plug power cord into a properly grounded wall outlet (Figure 79).



FIG. 79

For models equipped with off-board chargers, first connect the charger's DC cord into the machine's battery charge receptacle then plug the AC power supply cord into a properly grounded wall outlet (Figure 80). Refer to the off-board battery charger's owner manual for operating instructions.

**FOR SAFETY: Do not disconnect the off-board charger's DC cord from the machine's receptacle when the charger is operating. Arcing may result. If the charger must be interrupted during charging, disconnect the AC power supply cord first.**



FIG. 80

- The charger will automatically begin charging and shut off when fully charged. The maximum charging cycle may take up to 6- 12 hours depending on battery type.

On-board battery charger: The battery discharge indicator lights will ripple back and forth during the charging cycle. When all five lights repeatedly flash two times, the charging cycle is complete (Figure 81).

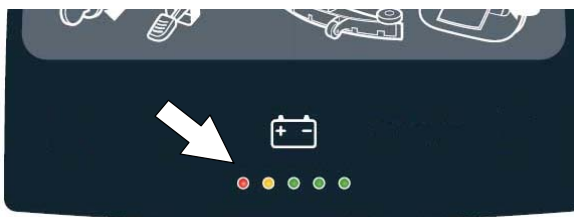

FIG. 81

- After charging batteries unplug the power supply cord and wrap cord around the cord hooks (Figure 82).

For models equipped with an off-board charger, always disconnect the AC power supply cord first before disconnecting charger from machine.



FIG. 82

## BATTERY CHARGER SETTINGS

*NOTE: The following instructions apply to models equipped with flooded lead- acid or sealed AGM batteries.*

The battery charger is set to charge the battery type supplied with your machine. If you choose to change to a different battery type or capacity, the charger's charging profile must be changed to prevent battery damage.

The machine's battery discharge indicator (BDI) must also be reprogrammed to match battery type to prevent battery damage and/or short run- time.

*NOTE: For machines shipped without batteries, the battery discharge indicator and the on- board battery charger are set for GEL batteries as the default. If you choose to use a different battery type, the settings must be changed as described as below.*

*NOTE: For machines shipped without batteries and supplied with an Off- Board Charger, the off- board battery charger is set for wet lead- acid batteries from the factory. The machine's battery discharge indicator is set for GEL batteries as the default. The machine's battery discharge indicator must be reprogrammed to match charger settings (See OFF-BOARD BATTERY CHARGER below).*

### OFF- BOARD BATTERY CHARGER:

To change the off- board battery charger settings, refer to the off-board charger's owner manual.

To reprogram the machine's battery discharge indicator (BDI) service application software is required, contact service.

### ON- BOARD BATTERY CHARGER:

To change the on- board battery charger settings, service application software is required, contact service. As an alternative, the charger settings may be manually changed as describe below. The battery discharge indicator will automatically reprogram to match battery type when the battery charger profile is changed.

### **CHANGING ON- BOARD BATTERY CHARGER SETTINGS**

To manually change the on-board battery charger settings for a different battery type, carefully follow instructions as described below :

*NOTE: The manual method is only an alternative if unable to change setting by use of the Service Application Software performed by Service.*

1. Disconnect battery cables (Figure 83).

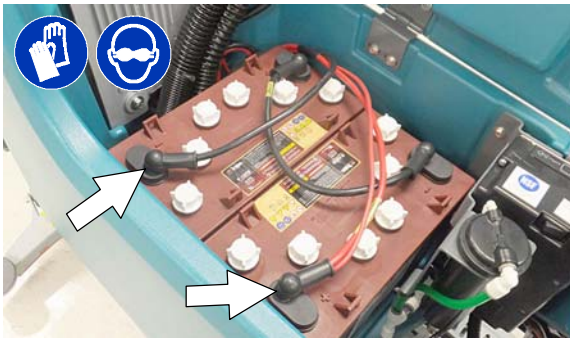

**FIG. 83**

2. Unwrap the battery charger power cord from the cord hooks.
3. Using a T25 star screwdriver, remove the two screws located at the bottom of the control console to access battery charger (Figure 84).

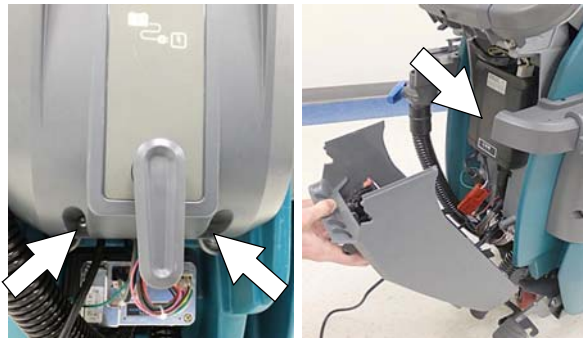

**FIG. 84**

4. Disconnect the battery cable, power cord and wire harness from charger. Using a T25 star screwdriver, remove the four screws that mount charger to machine (Figure 85). Remove charger from machine.

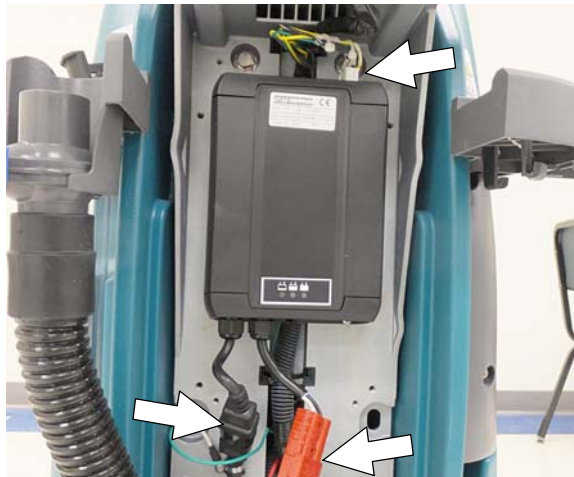

**FIG. 85**

5. Remove the black cap from bottom side of charger to access the profile dial (Figure 86)

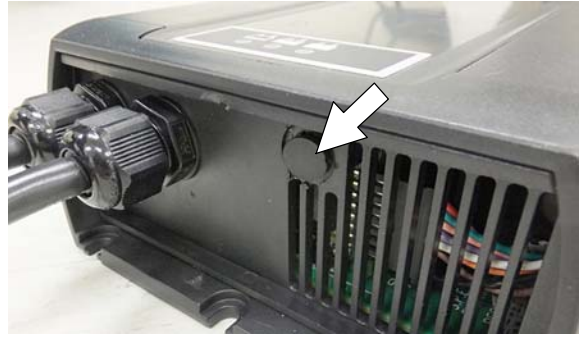

**FIG. 86**

6. Using a small standard screwdriver, turn the dial to the appropriate battery type according to the following chart (Figure 87).



**FIG. 87**

Dial Position	Battery Description Settings with AH Ranges
0	CAN- BUS setting*
1	Wet, Trojan 105- 155 AH
2	Wet, EnerSys/Tab 105- 155 AH
3	AGM, Discover 80- 150 AH
4	AGM, Fullriver 80- 150 AH
5	AGM, TPPL, EnerSys 20- 40 AH
6	Gel, Sonnenschein 80- 150 AH

\* The CAN-BUS setting, dial position "0", is the software setting that is programmed to match battery type supplied with machine. When the dial is manually changed to a different setting, it should not be reset back to "0" otherwise battery damage may result. Service Application Software is required to reset dial back to "0". Contact Service.

7. Replace the black cap on charger, reinstall battery charger and replace control console.
8. Reconnect the battery cable connection.
9. To set the BDI for the new battery type, plug the on-board battery charger cord into an electrical outlet. The machine's software will automatically reprogram the BDI to the new battery type.

**MANUAL BATTERY WATERING SYSTEM  
(Trojan Battery OPTION)**

The following instructions are for models equipped with the manual battery watering system option.

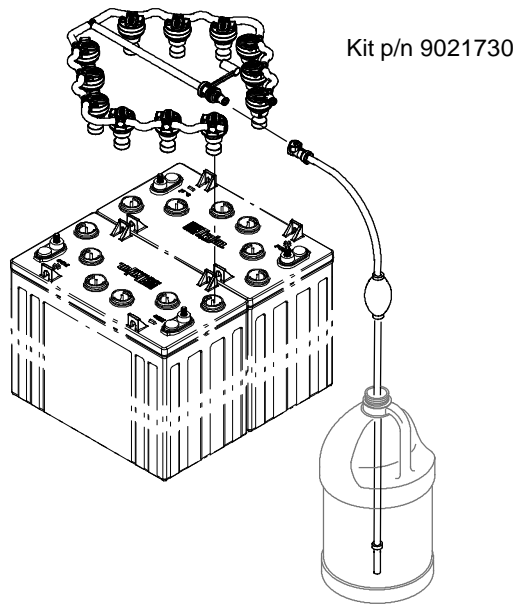

The optional manual battery watering system provides a safe and easy way to maintain the proper electrolyte levels in your batteries. It is designed exclusively for Trojan flooded (wet) lead-acid batteries.

**FOR SAFETY: When servicing machine, wear personal protection equipment as needed. Avoid contact with battery acid.**

Before using the battery watering system check hoses and connections for damage or wear.

1. Fully charge batteries prior to using the battery watering system. Do not add water to batteries before charging, the electrolyte level will expand and may overflow when charging.
2. After charging batteries, check the electrolyte level indicator on each battery cap. If any of the indicator floats are low, add water as described in the next step (Figure 88).

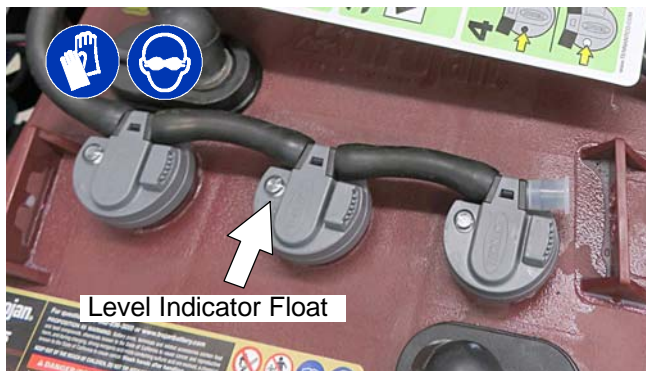
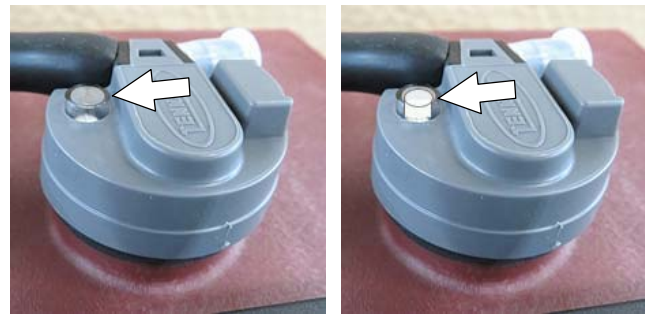

FIG. 88

3. If the level indicator has a low white float add water as described in the following instructions. (Figure 89).



Low Float = Add Water

High Float = Full

FIG. 89

4. Locate the battery fill hose coupler inside the battery compartment. Remove the dust cap and connect the hand pump hose (Figure 90).



FIG. 90

5. Submerge the other end of the hand pump hose into a bottle of distilled water (Figure 91).



FIG. 91

## MAINTENANCE

6. Squeeze the bulb on the hand pump hose until firm. The indicator float will rise when full (Figure 92).

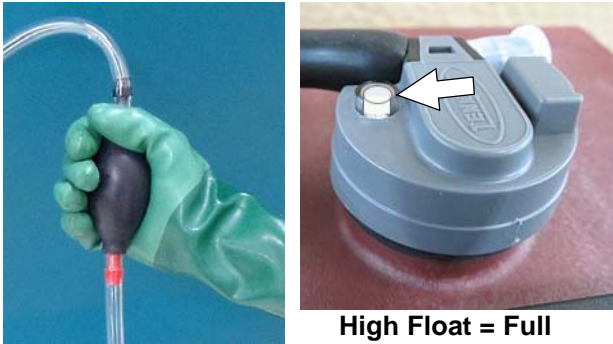

FIG. 92

7. After adding water, replace the dust cap on the battery watering distribution hose and store the hand pump hose inside the machine's battery compartment for future use.

## SQUEEGEE BLADE REPLACEMENT

**FOR SAFETY: Before leaving or servicing machine, stop on level surface, turn off machine, remove key and set parking brake if equipped.**

Each squeegee blade has four wiping edges. When the blades become worn, simply rotate the blades end-for-end or top-to-bottom for a new wiping edge. Replace blade if all four edges are worn.

1. Remove the squeegee assembly from the machine.
2. Fully loosen the two outside knobs on squeegee assembly. This will separate the spring loaded blade retainer from squeegee frame (Figure 93). To loosen the knobs quickly, squeeze the blade retainer and squeegee frame together.

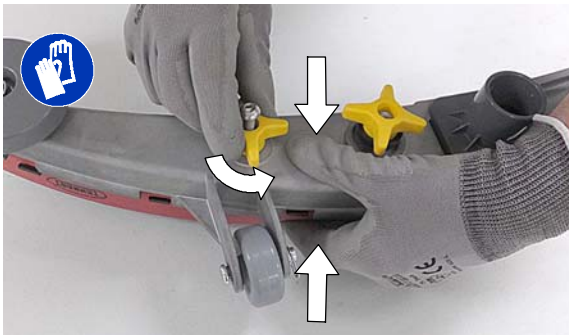

FIG. 93

3. Remove worn blade(s) from the blade retainer (Figure 94).

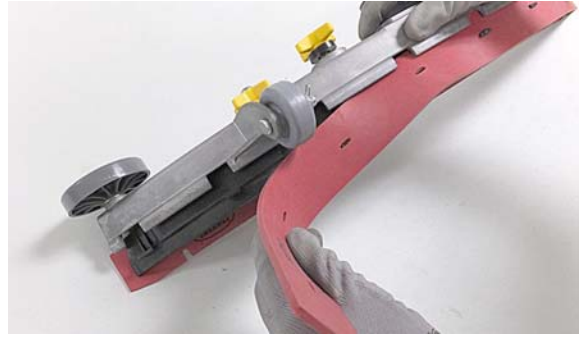

FIG. 94

4. Rotate the rear blade to a new wiping edge (Figure 95). Make sure to align the slots in the blade with retainer tabs.

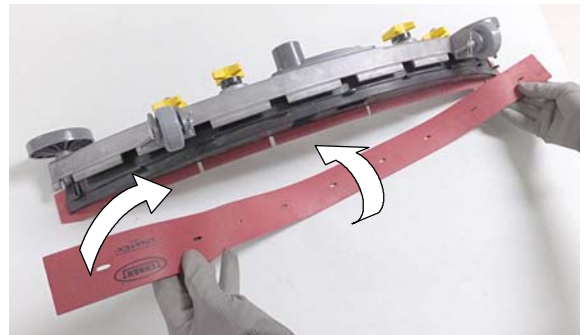

FIG. 95

5. Squeeze the squeegee frame and blade retainer together and re-tighten the two outside knobs (Figure 96).



FIG. 96

## ec-H2O NanoClean WATER CONDITIONING CARTRIDGE REPLACEMENT

**FOR SAFETY: Before leaving or servicing machine, stop on level surface, turn off machine, remove key and set parking brake if equipped.**

The water conditioning cartridge is required to be replaced when it reaches its maximum water usage or expiration time of when the cartridge was activated, whichever ever comes first. The control panel will signal a code when it's time to replace cartridge. See CONTROL PANEL OPERATION for further details.

Depending on machine usage, on average, a new cartridge can last anywhere from 12 months for heavy machine usage to 24 months for light machine usage.

**ATTENTION:** During first time use and after replacing the water conditioning cartridge, the ec-H2O system will automatically override the selected solution flow rate for up to 75 minutes.

1. Park the machine on a level surface, remove the key and set parking brake, if equipped.
2. Lift the recovery tank to access the ec-H2O water conditioning cartridge (Figure 97). Drain recovery tank before lifting tank.



FIG. 97

3. Disconnect the two hose connectors from the top of the cartridge by pressing the gray collars inward and pulling the connectors outward (Figure 98). Lift cartridge to remove.



FIG. 98

4. Fill in the installation date on the new cartridge label (Figure 99).

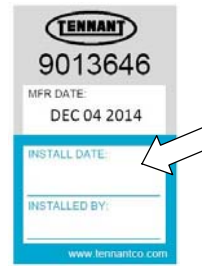

FIG. 99

5. Install the new cartridge and reconnect the two hoses. Make sure the hose connectors are fully inserted into the cartridge.

6. Reset timer for new cartridge.

Carefully read and understand all steps first before performing procedure.

- a. Turn key on.
- b. Press and hold the service switch, located on the ec-H2O module, for 10 seconds. After releasing service switch, the three solution flow indicator lights will begin to (ripple) move back and forth (Figure 100).
- c. Within 5 seconds after releasing the service switch, while the three indicator lights are moving back and forth, quickly press and release the solution flow button located on ec-H2O module (Figure 100).

The three indicator lights will then blink three times to indicate timer has been reset.

Repeat process if the three indicator lights do not blink three times.

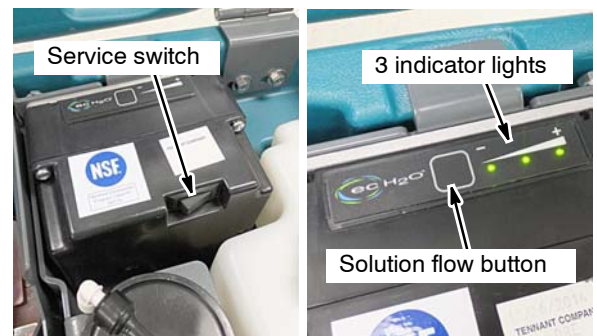

FIG. 100

### LOADING/UNLOADING MACHINE FOR TRANSPORTING

When transporting the machine by use of trailer or truck, carefully follow the loading and tie-down procedure:

1. Raise the scrub head and remove squeegee assembly.
2. Use a ramp that can support the machine weight and operator and carefully load machine. Do not operate the machine on a ramp incline that exceeds a 21% grade level (Figure 101). A winch must be used when ramp incline exceeds a 21% grade level.

**FOR SAFETY: When loading/unloading machine onto/off truck or trailer, use a ramp that can support the machine weight and operator.**

**FOR SAFETY: Do not operate the machine on a ramp incline that exceeds a 21% grade level.**

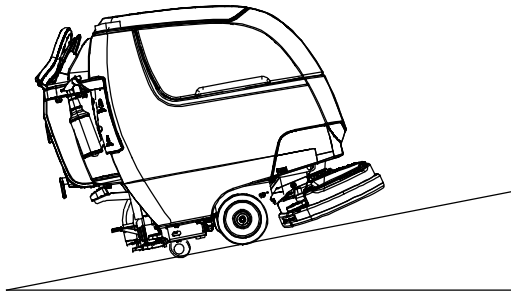

FIG. 101

3. Once loaded, position the front of the machine up against the front of the trailer or truck. Lower the scrub head, turn key off and set parking brake, if equipped (Figure 102).
4. Place a block behind each wheel (Figure 102).
5. Using tie-down straps, secure the machine using the four tie-down brackets located on the machine frame (Figure 102). It may be necessary to install tie-down brackets to the floor of your trailer or truck.

**ATTENTION: Do not use control console area or accessory storage rails for tie-down locations, damage may occur.**

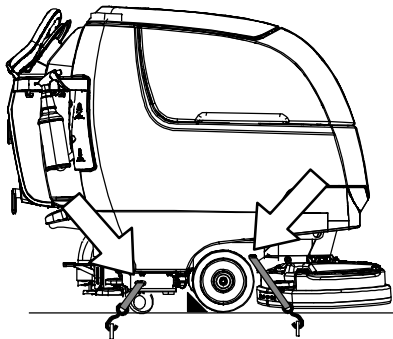

FIG. 102

### STORING MACHINE

The following steps should be taken when storing the machine for extended periods of time.

1. Charge the batteries before storing machine to prolong the life of the batteries. Recharge lead-acid batteries once a month. Recharge Lithium-ion batteries once a year.
2. Disconnect batteries before storing.
3. Lithium-ion batteries: Turn off battery power with the battery power button.
4. Drain and rinse recovery tank and solution tank.
5. Store the machine in a dry area with squeegee and scrub head in the up position.

**ATTENTION: Do not expose machine to rain, store indoors.**

6. Open the recovery tank lid to promote air circulation.
7. If storing machine machine in freezing temperatures, proceed to FREEZE PROTECTION.

**FOR SAFETY: When storing Lithium-ion Battery Model, do not expose battery to temperatures below -22°F/-30°C, above 140°F/60°C. Do not use machine immediately after long-term extreme temperature storage. Before use, return battery module temperature range to 50°F/10°C~95°F/35°C**

*NOTE: To prevent potential machine damage store machine in a rodent and insect free environment.*

The following steps should be taken when storing the machine for extended periods of time.

#### FREEZE PROTECTION

Storing machine in freezing temperatures.

1. Completely drain solution tank and recovery tank.
2. Empty the water from the solution tank filter located under machine. Replace filter.
3. Pour 1 gallon / 4 liters of propylene glycol based recreational vehicle (RV) antifreeze into the solution tank.
4. Turn machine on and operate the solution flow system. Turn the machine off when the antifreeze is visible on floor.

Models equipped with ec-H2O option - Operate ec-H2O scrubbing to cycle antifreeze through system.

5. After storing machine in freezing temperatures, drain any remaining antifreeze from the solution tank. Add clean water to solution tank and operate the machine to flush system.

**TROUBLESHOOTING**

<b>PROBLEM</b>	<b>CAUSE</b>	<b>SOLUTION</b>
Service indicator icon is blinking	Machine or on-board battery charger fault has been detected	See SERVICE INDICATOR CODES
ec-H2o indicator icon is red or blinking red	ec-H2O system fault has been detected	See SERVICE INDICATOR CODES
Machine will not operate	Emergency stop button activated	Turn button to reset
	Machine fault detected	See SERVICE INDICATOR CODES
	Batteries discharged	Recharge batteries
	Loose battery cable(s)	Tighten loose cables
	Faulty battery(s)	Replace battery(s)
	Faulty key switch	Contact service
	Faulty start bail switch	Contact service
	Circuit breaker tripped	Reset circuit breaker
On-board battery charger will not operate	Faulty control board	Contact service
	Plug not connected to power supply	Check plug connection
	Batteries over discharged	Replace batteries
	Battery charger fault detected	See SERVICE INDICATOR CODES
Machine will not propel (Drive Model)	Faulty charger	Replace charger
	Propel fault has been detected.	See SERVICE INDICATOR CODES
	Circuit breaker tripped	Reset circuit breaker
	Faulty propel motor or wiring	Contact service
Brush motor will not operate	Worn carbon brushes in motor	Contact service
	Brush motor fault has been detected.	See SERVICE INDICATOR CODES
	Faulty pad motor or wiring	Contact service
	Circuit breaker tripped	Reset circuit breaker
	Worn carbon brushes in motor	Contact service
Vacuum motor will not operate	Broken or loose belt (dual disk/cylindrical models)	Contact service
	Squeegee assembly is raised off floor	Lower squeegee assembly to floor
	Vacuum motor fault has been detected	See SERVICE INDICATOR CODES
	Faulty vacuum motor or wiring	Contact service
Poor scrubbing performance	Circuit breaker tripped	Reset circuit breaker
	Debris caught in brush/pad	Remove debris
	Worn brush/pad	Replace brushes/pad
	Incorrect brush pressure	Adjust brush pressure
	Wrong brush/pad type	Use correct brush/pad for application
	Low battery charge	Recharge batteries

# MAINTENANCE

## TROUBLESHOOTING - Continued

PROBLEM	CAUSE	SOLUTION
Trailing water - poor or not water pickup	Full recovery tank or excessive foam buildup	Drain recovery tank
	Loose drain hose cap or flow control valve is open	Replace cap or close flow control valve on drain hose
	Worn squeegee blades	Rotate or replace squeegee blades
	Clogged drip trap (Squeegee assembly)	Remove cover and clean
	Clogged squeegee assembly	Clean squeegee assembly
	Loose vacuum hose connection	Secure vacuum hose connection
	Clogged vacuum hose	Flush vacuum hose
	Clogged vacuum hose	Flush vacuum hose
	Damaged vacuum hose	Replace vacuum hose
	Clogged float shut-off screen in recovery tank	Clean screen
	Recovery tank lid not completely closed	Check lid for obstructions
Defective seals on recovery tank lid	Replaced seal	
Little or no solution flow	Empty solution tank	Refill solution tank
	Low solution flow rate set	Increase solution flow rate
	Clogged solution tank filter	Clean filter
	Plugged solution supply line	Flush solution supply line
Short run time	Low battery charge	Charge batteries
	Batteries need maintenance	See BATTERIES
	Defective battery or end of battery life	Replace batteries
	Battery discharge indicator (BDI) programmed incorrectly	See CHARGING BATTERIES
	Faulty charger	Replace battery charger
	Brush pressure set too high	Lower brush pressure. Lower dual down pressure lever if equipped

**GENERAL MACHINE DIMENSIONS/CAPACITIES/PERFORMANCE**

MODEL	17 in / 43 cm Disk (Push)	20 in / 50 cm Disk (Push)	17 in / 43 cm Disk (Drive)	20 in / 50 cm Disk (Drive)
Length	51.25 in / 1302 mm	54 in / 1372 mm	51.25 in / 1302 mm	54 in / 1372 mm
Width	20 in / 508 mm	22 in / 559 mm	20 in / 508 mm	22 in / 559 mm
Height	43.1 in / 1095 mm	43.1 in / 1095 mm	43.1 in / 1095 mm	43.1 in / 1095 mm
Weight	220 lb / 98 kg	230 lb / 104 kg	230 lb / 104 kg	240 lb / 109 kg
Weight (with batteries)	366 lb / 166 kg	376 lb / 171 kg	390 lb / 177 kg	400 lb / 181 kg
GVW	457 lb / 207 kg	467 lb / 212 kg	482 lb / 219 kg	492 lb / 223 kg
Squeegee width	30.4 in / 772 mm			
Recovery tank capacity	14 gal / 53 L			
Solution tank capacity	11 gal / 42 L			
Scrubbing path width	16.9 in / 430 mm	19.9 in / 505 mm	16.9 in / 430 mm	19.9 in / 505 mm
Down pressure	47 lbs / 21.3 kg	52 lbs / 23.5 kg	47 lbs / 21.3 kg	51 lbs / 23 kg
Dual down pressure	88 lbs / 40 kg	92 lbs / 41.7 kg	86 lbs / 39 kg	90 lbs / 41 kg
Scrubbing speed	Pad assist		200 fpm / 61 mpm	
Transport speed	n/a	n/a	240 fpm / 73 mpm	
Reverse speed	n/a	n/a	144 fpm / 44 mpm	
Productivity rate - estimated actual	9,340ft <sup>2</sup> /hr / 868m <sup>2</sup> /hr	11,208ft <sup>2</sup> /hr / 1041m <sup>2</sup> /hr	12,453ft <sup>2</sup> /hr / 1157m <sup>2</sup> /hr	14,943ft <sup>2</sup> /hr / 1388m <sup>2</sup> /hr
ec-H <sub>2</sub> O productivity rate - est. actual	9,668 ft <sup>2</sup> /hr / 898 m <sup>2</sup> /hr	11,602ft <sup>2</sup> /hr / 1078m <sup>2</sup> /hr	12,891ft <sup>2</sup> /hr / 1198m <sup>2</sup> /hr	15,469ft <sup>2</sup> /hr / 1437m <sup>2</sup> /hr
Aisle turnaround width	52 in / 1321 mm	54.5 in / 1384 mm	52 in / 1321 mm	54.5 in / 1384 mm
Ramp incline for scrubbing	9% maximum			
Ramp incline for transporting	21% maximum			
Ramp incline for loading- empty tanks	21% maximum			
Solution flow rate - T300e	.5 gpm / 1.9 L/min maximum			
ec-H <sub>2</sub> O solution flow rate	Low: .12 gpm / .45 L/min, Med: .25 gpm / .94 L/min, High: .35 gpm / 1.3 L/min			
Brush motor	24 VDC, .68hp / .50kW			
Propel motor	n/a	n/a	24 VDC, .23 hp / .175 kW	
Vacuum motor	24 VDC, .5hp / .37kW			
Water lift	34.5 in / 876 mm			
ec-H <sub>2</sub> O solution pump	24 VDC, 1.0 gpm / 3.8 L/min, min open flow			
Machine voltage	24 VDC			
Battery capacity	2- 12V 105AH C/20 Wet, 2- 12V 130AH C/20 Wet, 2- 12V 150AH C/20 Wet, 2- 12V 140AH C/20 Sealed/AGM, 1- 24V 90Ah Lithium- ion			
Total power consumption	31.5A nominal	36.5A nominal	34.5A nominal	39.5A nominal
Battery Charger - on-board	100- 240VAC, 50/60Hz, 24VDC, 13A			
Battery Charger - smart off-board	100- 240VAC, 50/60Hz, 24VDC, 13A			
Battery Charger - on-board (Lithium- ion battery model)	100- 240VAC, 50/60Hz, 24VDC, 27A			
Battery Charger - smart off-board (Lithium- ion battery model)	100- 240VAC, 50/60Hz, 24VDC, 27A			
Protection grade	IPX3			
Sound pressure level L <sub>pA</sub> *	67 dB(A)	67 dB(A)	67 dB(A)	67 dB(A)
Sound uncertainty K <sub>pA</sub> *	0.8 dB(A)	0.8 dB(A)	0.8 dB(A)	0.8 dB(A)
Sound power level uncertainty L <sub>pA</sub> - uncertainty K <sub>pA</sub> *	84.3 dB(A)	84.3 dB(A)	84.3 dB(A)	84.3 dB(A)
Machine vibration at hand-arm*	<2.5 m/s <sup>2</sup>			
Ambient operating temperature	Min: 32°F/0°C, Max: 110°F/43°C			

\*Values per EN 60335- 2- 72. Specifications are subject to change without notice.

# SPECIFICATIONS

## GENERAL MACHINE DIMENSIONS/CAPACITIES/PERFORMANCE

MODEL	24 in / 60 cm Dual Disk	20 in / 50 cm Cylindrical Brush	20 in / 50 cm Orbital
Length	51.75 in / 1314 mm	50.5 in / 1283 mm	49 in / 1245 mm
Width	26 in / 660 mm	25 in / 635 mm	20.5 in / 521 mm
Height	43.1 in / 1095 mm	43.1 in / 1095 mm	43.1 in / 1095 mm
Weight	250 lb / 113 kg	250 lb / 113 kg	255 lb / 116 kg
Weight (with batteries)	410 lb / 186 kg	410 lb / 186 kg	415 lb / 188 kg
GVW	502 lb / 228 kg	502 lb / 228 kg	507 lb / 230 kg
Squeegee width	30.4 in / 772 mm		
Recovery tank capacity	14 gal / 53 L		
Solution tank capacity	11 gal / 42 L		
Scrubbing path width	23.6 in / 600 mm	19.7 in / 500 mm	19.7 in / 500 mm
Down pressure	57 lbs / 26 kg	53 lbs / 24 kg	63 lbs / 28.5 kg
Dual down pressure	97 lbs / 44 kg	64 lbs / 29 kg	109 lbs / 49.5 kg
Scrubbing speed	200 fpm / 61 mpm		
Transport speed	240 fpm / 73 mpm		
Reverse speed	144 fpm / 44 mpm		
Productivity rate - estimated actual	18,264ft <sup>2</sup> /hr / 1697m <sup>2</sup> /hr	14,943ft <sup>2</sup> /hr / 1388m <sup>2</sup> /hr	14,943ft <sup>2</sup> /hr / 1388m <sup>2</sup> /hr
ec-H <sub>2</sub> O productivity rate - est. actual	18,906ft <sup>2</sup> /hr / 1756m <sup>2</sup> /hr	15,469ft <sup>2</sup> /hr / 1437m <sup>2</sup> /hr	15,469ft <sup>2</sup> /hr / 1437m <sup>2</sup> /hr
Aisle turnaround width	53.5 in / 1346 mm	52 in / 1321 mm	49 in / 1245 mm
Ramp incline for scrubbing	9% max.		
Ramp incline for transporting	21% max.		
Ramp incline for loading- empty tanks	21% max.		
Solution flow rate	.5 gpm / 1.9 L/min maximum		
ec- H <sub>2</sub> O solution flow rate	Low: .12 gpm / .45 L/min, Med: .25 gpm / .94 L/min, High: .35 gpm / 1.3 L/min		
Brush motor	24 VDC, .68hp / .50kW		
Propel motor	24 VDC, .23 hp / .175kW		
Vacuum motor	24 VDC, .5 hp / .37 kW		
Water lift	34.5 in / 876 mm		
ec- H <sub>2</sub> O solution pump	24 VDC, 1.0 gpm / 3.8 L/min, min open flow		
Machine voltage	24 VDC		
Battery capacity	2- 12V 105AH C/20 Wet, 2- 12V 130AH C/20 Wet, 2- 12V 150AH C/20 Wet, 2- 12V 140AH C/20 Sealed/AGM. 1- 24V 90Ah Lithium- ion		
Total power consumption	36A nominal	40A nominal	30A nominal
Battery Charger - on-board	100- 240VAC, 50/60Hz, 24VDC, 13A		
Battery Charger - smart off-board	100- 240VAC, 50/60Hz, 24VDC, 13A		
Battery Charger - on-board (Lithium- ion battery model)	100- 240VAC, 50/60Hz, 24VDC, 27A		
Battery Charger - smart off-board (Lithium- ion battery model)	100- 240VAC, 50/60Hz, 24VDC, 27A		
Protection grade	IPX3		
Sound pressure level L <sub>pA</sub> *	67.7 dB(A)	68.7 dB(A)	67.5 dB(A)
Sound uncertainty K <sub>pA</sub> *	0.8 dB(A)	0.8 dB(A)	0.8 dB(A)
Sound power level uncertainty L <sub>pA</sub> - uncertainty K <sub>pA</sub> *	83.8 dB(A)	84.2 dB(A)	83.5 dB(A)
Machine vibration at hand-arm*	<2.5 m/s <sup>2</sup>		
Ambient operating temperature	Min: 32°F/0°C, Max: 110°F/43°C		

\*Values per EN 60335- 2- 72. Specifications are subject to change without notice.

**MACHINE DIMENSIONS**

**SINGLE DISK MODEL**

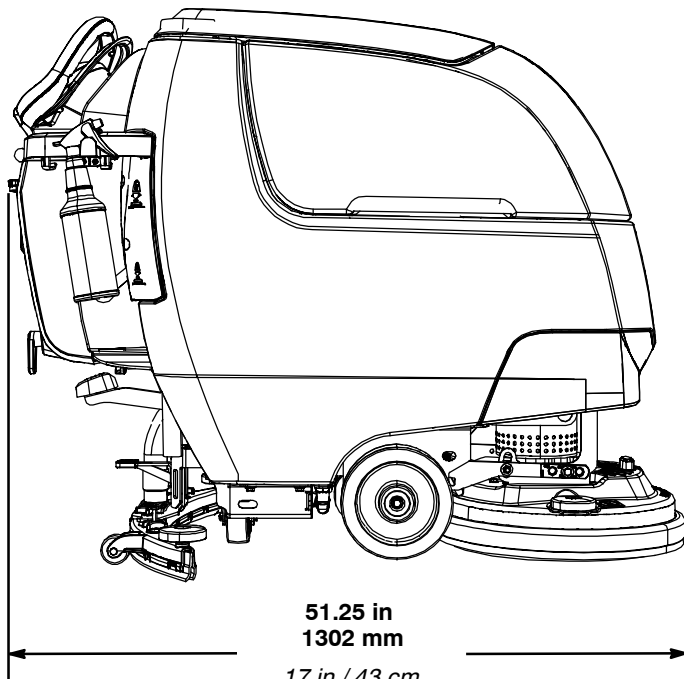
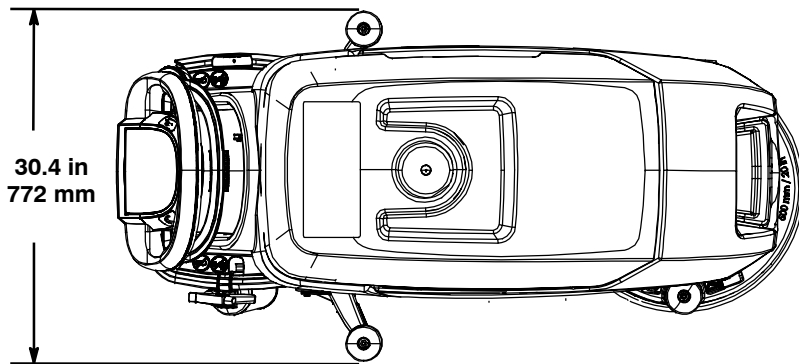

54 in  
1372 mm  
20 in / 50 cm  
Model

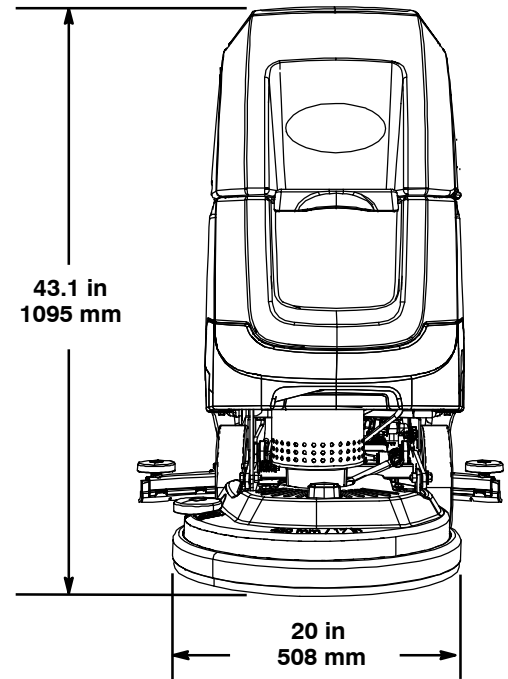

17 in / 43 cm  
Model  
22 in  
559 mm  
20 in / 50 cm  
Model

# SPECIFICATIONS

---

## DUAL DISK MODEL

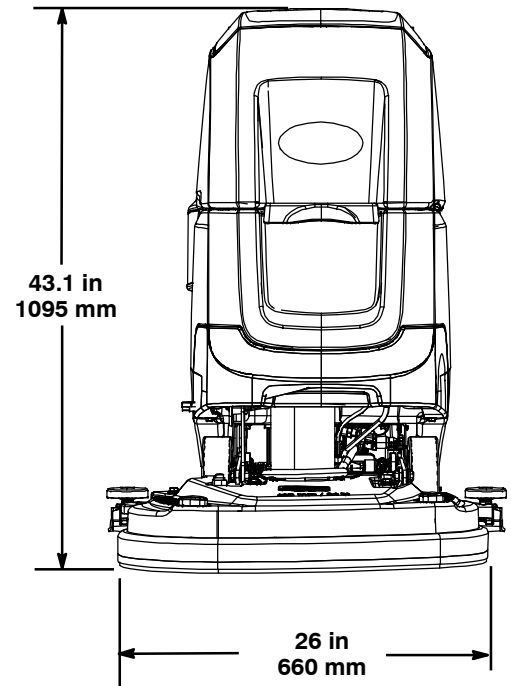
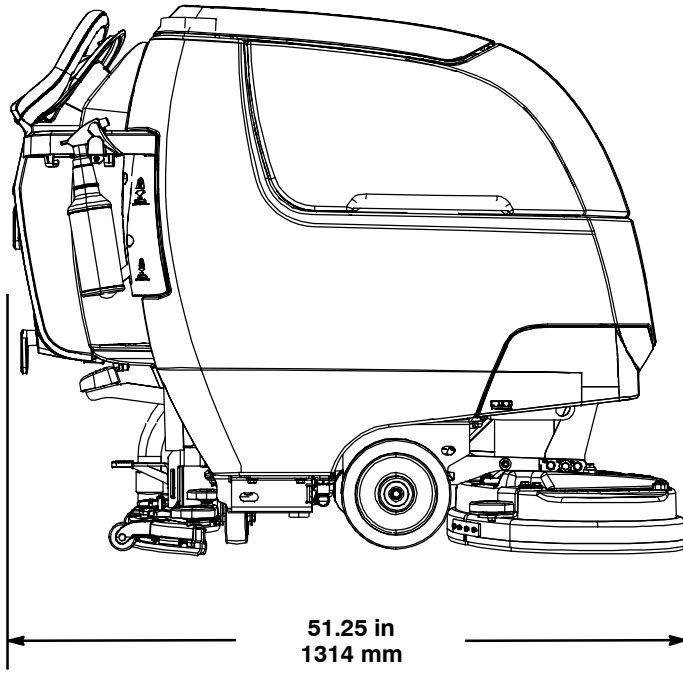
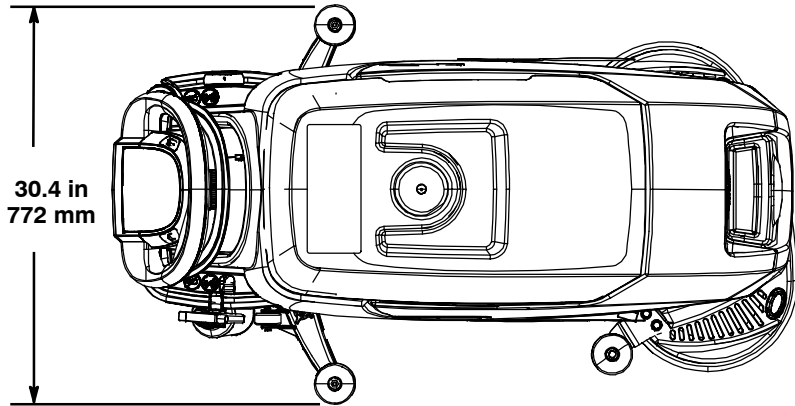

**CYLINDRICAL BRUSH MODEL**

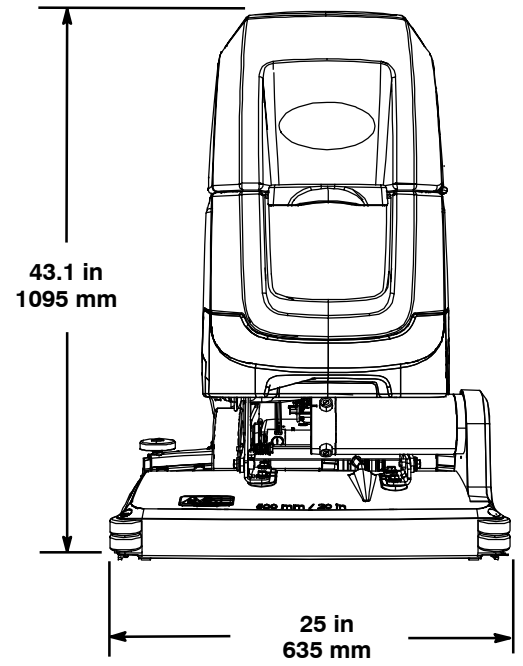
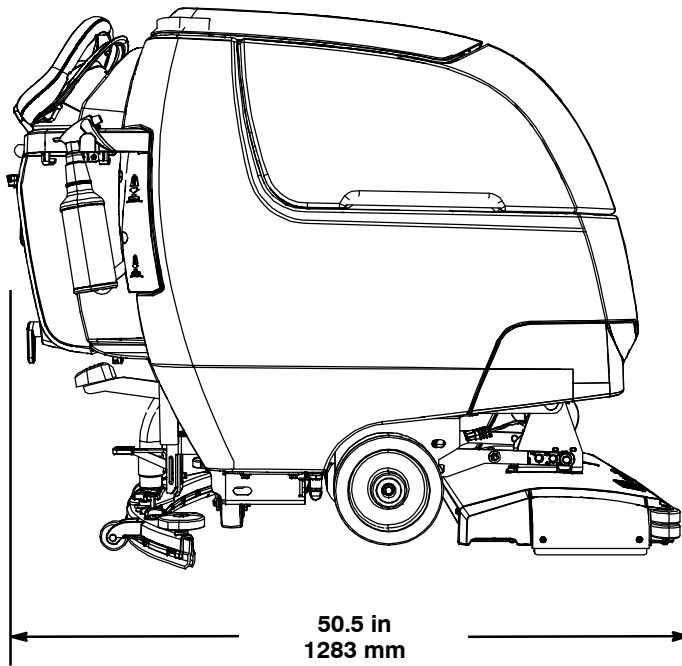
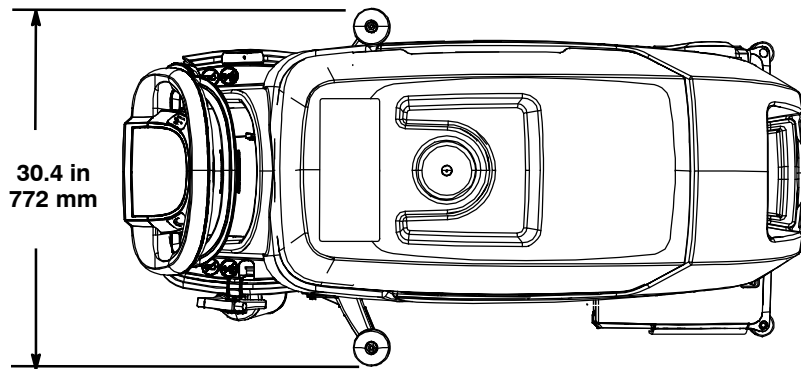

# SPECIFICATIONS

---

## ORBITAL PAD MODEL

